

Halsey Taylor Owners Manual

Model: 7130 Fountain

Marblyte Fountain

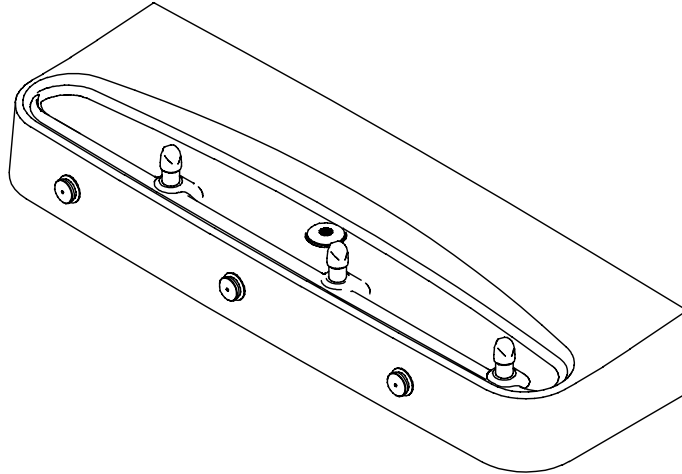

Installer

To assure you install this model easily and correctly, PLEASE READ THESE SIMPLE INSTRUCTIONS BEFORE STARTING THE INSTALLATION. CHECK YOUR INSTALLATION FOR COMPLIANCE WITH PLUMBING, ELECTRICAL AND OTHER APPLICABLE CODES. After installation, leave these instructions inside the fountain for future reference.

IMPORTANT

ALL SERVICE TO BE PERFORMED BY AN AUTHORIZED SERVICE PERSON

IMPORTANT! INSTALLER PLEASE NOTE.

THE GROUNDING OF ELECTRICAL EQUIPMENT SUCH AS TELEPHONE, COMPUTERS, ETC. TO WATER LINES IS A COMMON PROCEDURE. THIS GROUNDING MAY BE IN THE BUILDING OR MAY OCCUR AWAY FROM THE BUILDING. THIS GROUNDING CAN CAUSE ELECTRICAL FEEDBACK INTO A FOUNTAIN, CREATING AN ELECTROLYSIS WHICH CAUSES A METALLIC TASTE OR AN INCREASE IN THE METAL CONTENT OF THE WATER. THIS CONDITION IS AVOIDABLE BY USING THE PROPER MATERIALS AS INDICATED. ANY DRAIN FITTINGS PROVIDED BY THE INSTALLER SHOULD BE MADE OF PLASTIC TO ELECTRICALLY ISOLATE THE FOUNTAIN FROM THE BUILDING PLUMBING SYSTEM.

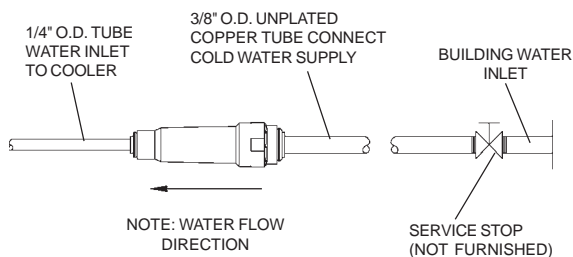

FIG. 1

OPERATION OF QUICK CONNECT FITTINGS

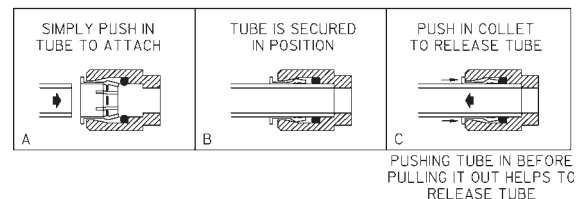
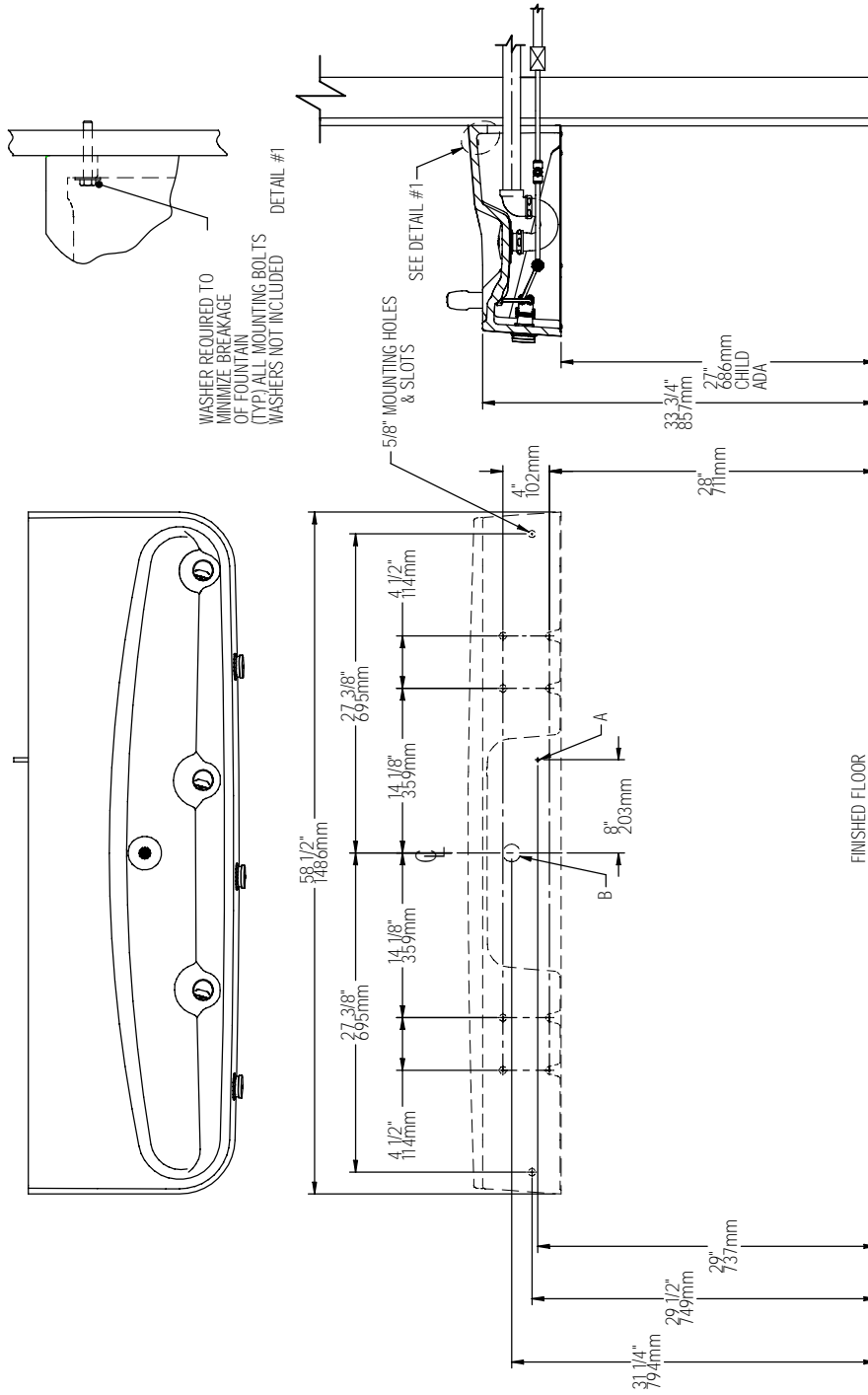
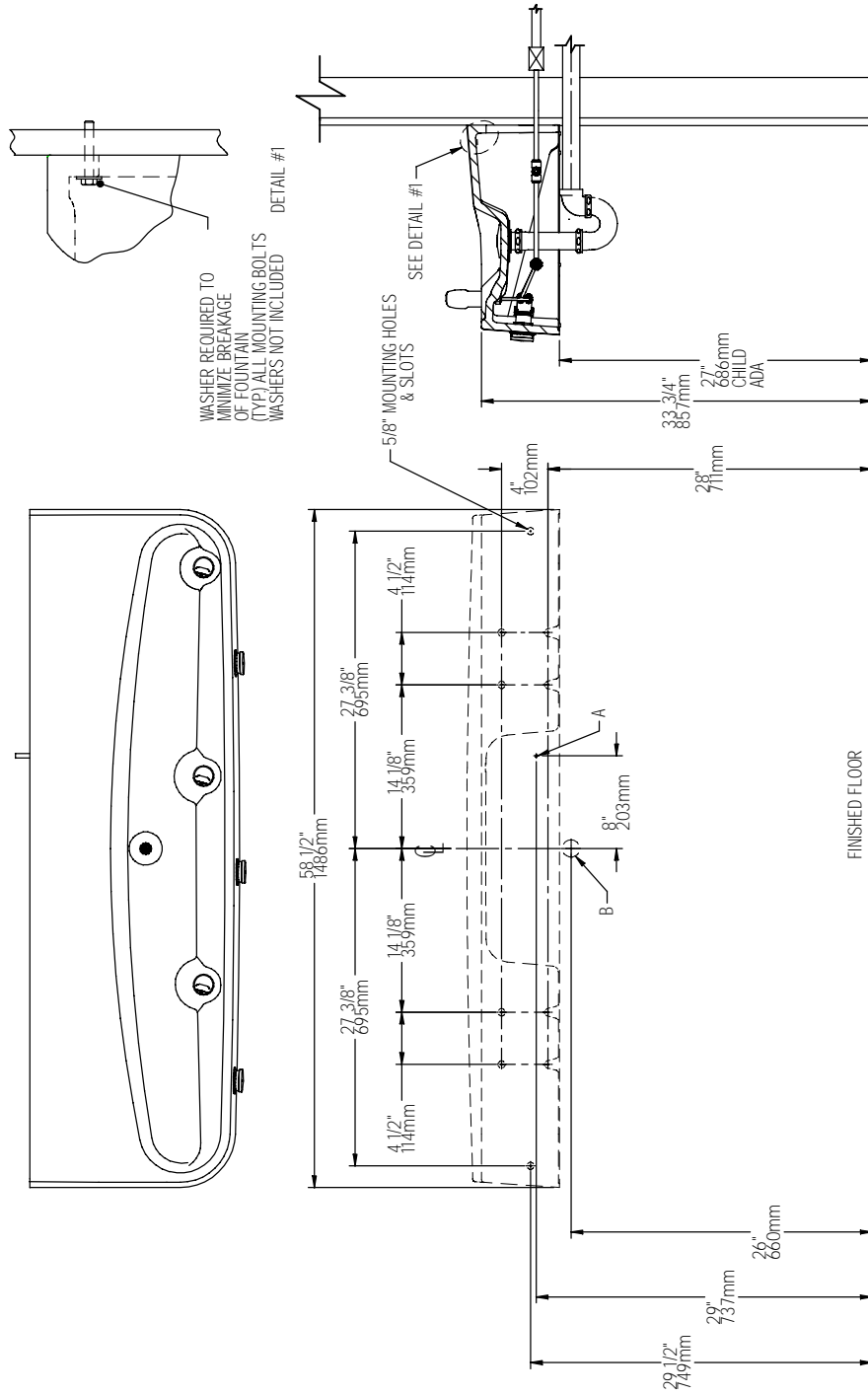

FIG. 2



LEGEND
 A = 3/8" O.D. UNPLATED COPPER TUBE CONNECT - SHUT OFF VALVE BY OTHERS
 B = WATER OUTLET 1-1/2" O.D. DRAIN - STUB OUT FROM WALL 1" (25mm)

FIG. 3



EXTERNAL TRAP

LEGEND
 A = 3/8" O.D. UNPLATED COPPER TUBE CONNECT - SHUT OFF VALVE BY OTHERS
 B = WATER OUTLET 1-1/2" O.D. DRAIN - STUB OUT FROM WALL 1" (25mm)

FIG. 4

INSTALLATION INSTRUCTIONS

1. Wall should already be framed for the fountain using the positioning dimensions shown in Figure 3 or 4. Shown dimensions pertain to installation location (framing must support up to 150 lbs. weight).
2. Install rough-in plumbing as shown in Figure 3 or 4. Run the supply water inlet line and connect to a service stop (not provided). Turn on supply water and flush thoroughly.
3. Remove bottom access panel from fountain basin and save the screws. Install the fountain to the wall using (10) 5/16" bolts and washers (not provided). Bolts should be long enough to securely fasten the fountain to the wall. Tighten securely, but do not over tighten. Over tightening will crack the fountain.
4. Remove elbow from end of p-trap and attach it to drain tube. Reattach elbow to p-trap and cut waste tube to required length using plumbing hardware and trap as a guide.
5. Make water supply connections from service stop to the 3/8" O.D. unplated copper tube coming out of the tee fitting). Turn on water supply and check for leaks. Newly installed water supply line should be insulated after leak check is completed. **DO NOT SOLDER TUBES INSERTED INTO THE TEE AS DAMAGE TO THE O-RINGS MAY RESULT.**
6. These products are designed to operate on 20-105 PSIG supply line pressure. If inlet pressure is above 105 PSIG, a pressure regulator must be installed in the supply line. Any damage caused by reason of connecting these products to supply line pressures lower than 20 PSIG or higher than 105 PSIG is not covered by warranty.
7. Check stream height from bubbler. Stream height is factory set at 40-50 PSI. If supply pressure varies greatly from this, adjust the screw on regulator (item 17) by using a small screwdriver through the small hole in the push button (item 8)(See Figure 5). Clockwise adjustment will raise stream height and counter-clockwise will lower stream height. For best adjustment stream height should be approximately 1-1/2" (38mm) above the bubbler guard.
8. Replace bottom access panel to fountain using the screws provided. Tighten securely.

CARE AND MAINTENANCE OF MARBLYTE FOUNTAINS

1. Marblyte provides an extremely durable, nonporous surface which resists staining. Care is very simple. Routine cleaning with a soft sponge or cloth, or with water or a non-abrasive aerosol foam cleaner, is all that is normally needed to give many years of trouble free service. Cleaners left standing on the fountain surface can dull the surface finish. Be certain to rinse all cleaning agents completely and polish with a soft cloth.
2. Harsh abrasive cleaners are not required and should not be used.
3. Mild abrasives such as liquid automotive cleaning compound or baking soda paste will remove simple scratches and stains. Cigarette burns can normally be removed without noticeable effect. Deeper scratches or gouges can be corrected with fine grit sandpaper (240 grit then 400 grit) or a green scotchbrite pad.
4. To maintain or regain luster and make cleaning easier, periodic applications of automobile wax or like products will keep the finish looking like new.

TROUBLE SHOOTING AND MAINTENANCE

1. **Orifice Assy:** Mineral deposits on orifice can cause water flow to spurt or not regulate. Mineral deposits may be removed from orifice with a small round file not over 1/8" diameter or a small diameter wire.
CAUTION: Do not file or cut orifice materials.
2. **Stream Regulator:** If orifice is free of material deposits, regulate flow according to instruction on page 3.
3. **Actuation of Quick Connect Water Fittings:** Cooler is provided with lead-free connectors which utilize an o-ring water seal. To remove tubing from the fitting, relieve water pressure, push in on the gray collar while pulling on the tubing (See Figure 2). To insert tubing, push tube straight into the fitting until it reaches a positive stop, approximately 3/4".

PARTS LIST		
ITEM NO.	PARTNO.	DESCRIPTION
1	45880C	DRAIN
2	75575C	ANTI-ROTATIONAL BALL
3	75570C	SCREW #10-24 PINNED TORX
4	15005C	NUT - REGULATOR RETAINING
5	28873C	BOTTOM - COVER
6	40045C	HEX NUT
7	55996C	IN-LINE STRAINER
8	45662C	PUSH BUTTON
9	45738C	PUSH BUTTON SLEEVE
10	50986C	REGULATOR HOLDER
11	98118C	BUBBLER ASSEMBLY
12	56087C	PUSH BUTTON EXTENSION
13	56293C	FOUNTAIN - GRANITE
14	61313C	REGULATOR
15	15028C	NIPPLE ASSEMBLY
16	70012C	HEX NUT - 3/8-18
17	75672C	SCREW - CAP #6-32 X 5/16
18	70852C	TEE - 3/8"
19	45873C	FERRULE - DRAIN
20	45736C	NUT - REGULATOR MOUNTING
21	55994C	1/4" POLY TUBING (CUT TO LENGTH)
22	56307C	3/8" POLY TUBING (CUT TO LENGTH)
23	45881C	6" TAIL PIPE
24	45879C	T-PIPE 1-1/2 X 1-3/16
25	56304C	GASKET - T-PIPE

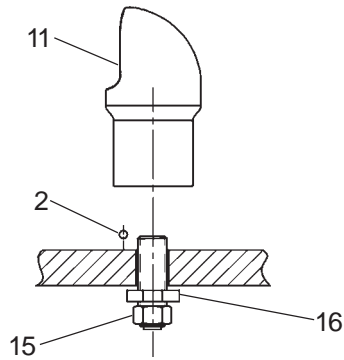

FIG. 6

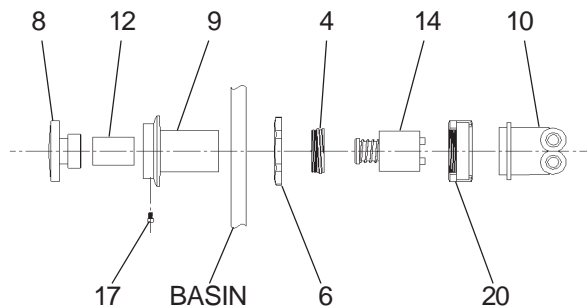
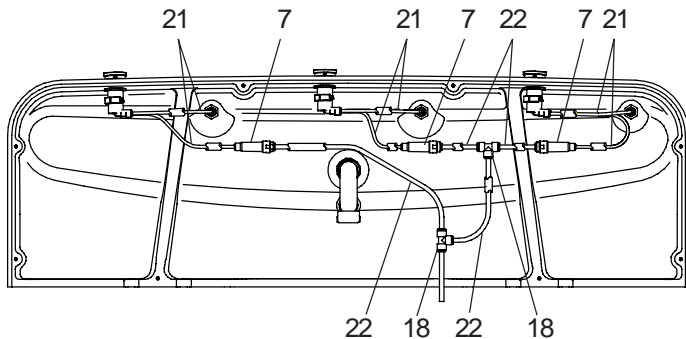
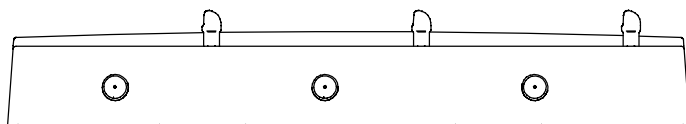
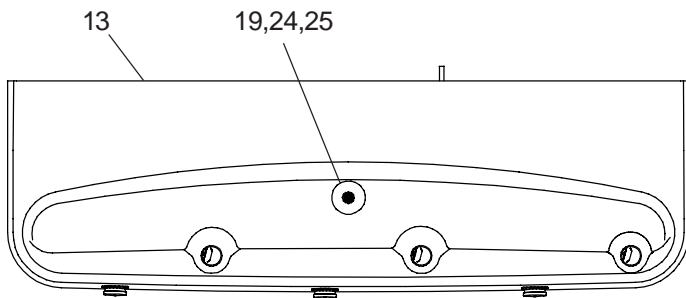
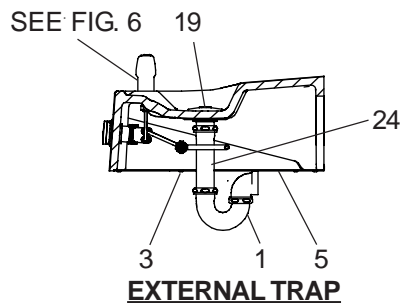
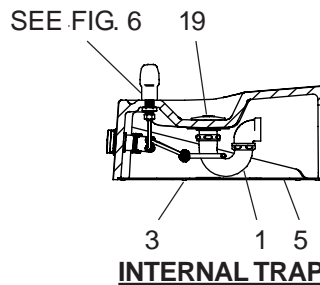

FIG. 5



**BOTTOM COVER
REMOVED**



Halsey Taylor
2222 CAMDEN COURT
OAK BROOK, IL 60523
630.574.3500

PRINTED IN U.S.A.