



# model 3377BFG

Bottle Filler Attachment

## FEATURES & BENEFITS

### QUALITY CONTROL

Pre-built fountain is pressure tested to ensure no leaks and proper functionality.

### GALVANIZED FINISH

Tough galvanized coating is ideal for areas where rusting is an issue, and vandalism and graffiti could be present. Due to the galvanizing process, appearance will be a rough, unfinished galvanized surface.

### DRINKING FOUNTAIN VALVE

The push-button activated valve offers the only all stainless steel valve body that is machined out of solid bar stock, is fully serviceable through the front of the push button assembly offering access to the water control cartridge and integral water supply strainer, and with front access to the water stream height adjustment for easy maintenance without having to remove the valve. Operating pressure range of 30 to 90 psi (2.1 to 6.2 bar).

### LAMINAR FLOW

Adjustable, splash-free, 1 gpm (3.78 L) laminar water flow.

### CONSTRUCTION

Heavy-duty 3/16" (.47 cm) galvanized steel pedestal attachment is supplied with a top down access plate.

### ATTACHMENT INSTALLATION

Bottle filler attachment can be ordered with a 3377G pedestal drinking fountain, or added to an existing installation.

### FOUNTAIN PUSH BUTTON

All chrome plated brass push button resists vandalism by allowing it to spin without unscrewing.



## SPECIFICATIONS

Model 3377BFG bottle filler attachment for the 3377G pedestal drinking fountain shall include a 14 gauge Type 304 Stainless Steel bottle filler bracket, 3/16" galvanized steel top-access pedestal extension, 100% lead-free waterways, 1 gpm (3.8 L) laminar flow, push-button operated stainless steel valve with front-accessible cartridge and flow adjustment, and vandal-resistant bottom plate. Appearance of galvanized finish may vary. May be an accessory to a new 3377G pedestal drinking fountain or retrofit to an existing 3377G.

## OPTIONS

- ❑ Bottle Filler Attachment: Model 3377BFFR, freeze-resistant, bottle filler attachment comes with push button operation, 3/16" galvanized steel top-access pedestal extension with green powder-coated finish, and a vandal resistant bottom plate.
- ❑ Bottle Filler Attachment: Model 3377BF, bottle filler attachment for the Haws 3377 pedestal fountain utilizes a satin finish stainless steel bracket, 100% lead-free waterways, laminar flow, and painted galvanized steel pedestal extension.

For more information, visit [www.hawsc.com](http://www.hawsc.com) or call (888) 640-4297.

## APPLICATIONS

Perfect for either public or private outdoor settings, the 3377BFG is a great fit in areas where aesthetics are important to the overall appeal of the architecture. Suitable in areas where weather conditions exist, this series stands strong as a nice addition to any community. This type of pedestal bottle filler may also be placed in a variety of settings such as parks, schools, and other outdoor environments where the temperature remains above freezing. Haws® manufactures drinking fountains and electric water coolers to be lead-free by all known definitions including NSF/ANSI Standard 61, Section 9, NSF/ANSI 372, California Proposition 65, and the Federal Safe Drinking Water Act. Product is compliant to California Health and Safety Code 116875 (AB 1953-2006).



**INSTALLATION INSTRUCTIONS:**

- 1) VERIFY THAT THE WATER SUPPLY IS SHUT OFF TO THE FOUNTAIN.
- 2) REMOVE THE ACCESS PLATE FROM THE EXISTING 3377 PEDESETAL. CUT THE EXISTING 3/8" PLASTIC WATER SUPPLY LINE AND INSTALL THE 3/8" TEE WITH THE 24" TUBE EXTENSION COMING OUT THE TOP.
- 3) FEED THE WATER SUPPLY TUBE THROUGH HOLE IN THE BOTTOM PLATE OF THE PEDESTAL EXTENSION. BOLT THE PEDESTAL EXTENSION ONTO THE 3377 FOUNTAIN USING THE (4) 1/4-20 FLATHEAD BOLTS PROVIDED. A BALL-END HEX WRENCH IS RECOMMENDED FOR BOLT INSTALLATION.
- 4) INSTALL THE BOTTLE FILLER BRACKET ONTO THE PEDESTAL USING THE (4) 3/8-16 HEX BOLTS PROVIDED. CONNECT THE SUPPLY LINE TUBE TO THE PUSH BUTTON VALVE.
- 5) RE-INSTALL THE ACCESS PLATE ON TOP THE PEDESTAL EXTENSION.

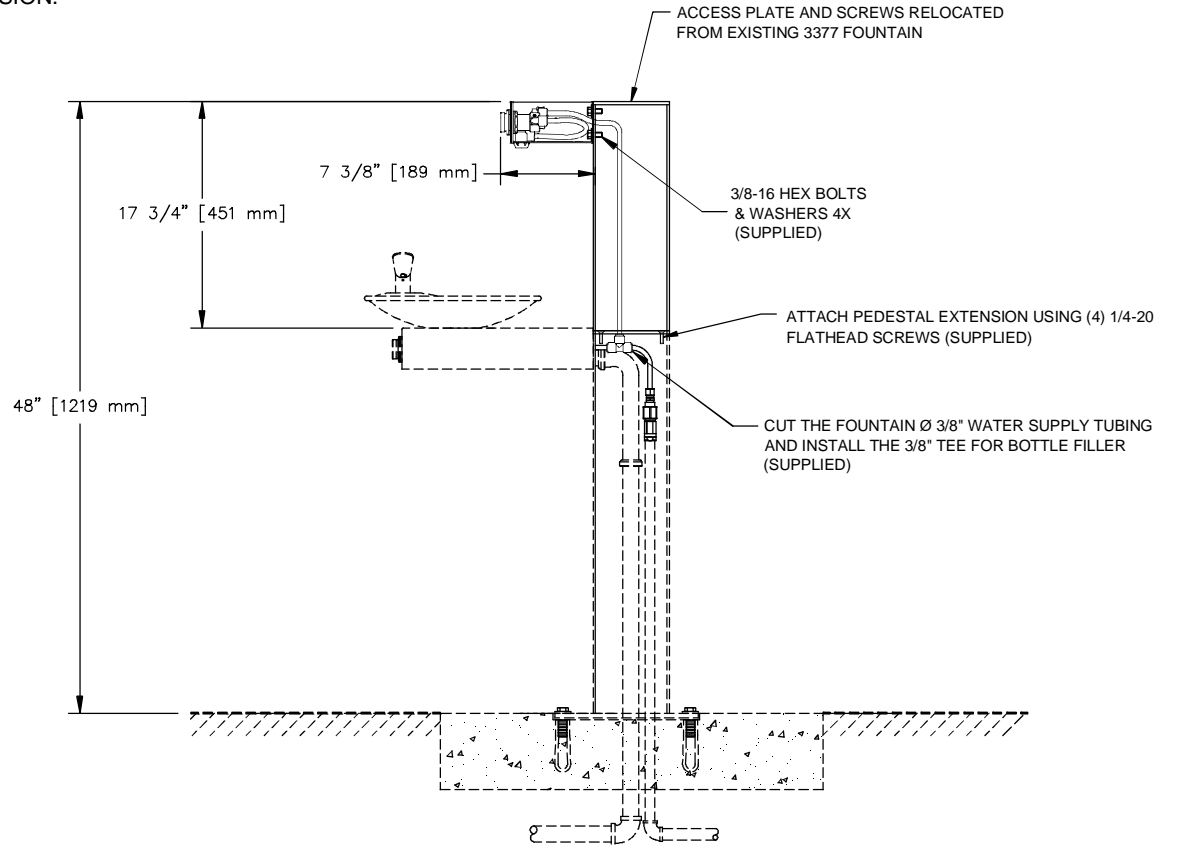
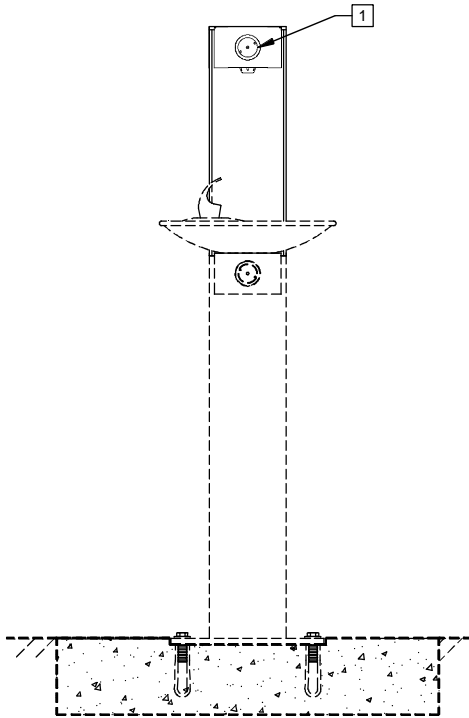
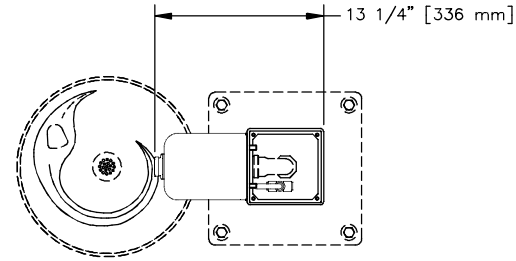

**NOTES:**

- 1 REFER TO 5874HF OPERATION AND MAINTENANCE MANUAL FOR PUSH BUTTON AND VALVE INSTALLATION/MAINTENANCE INSTRUCTIONS.

		<b>Haws</b> <sup>®</sup>		1455 KLEPPE LANE SPARKS, NEVADA 89431 (775) 359-4712 FAX (775) 359-7424 E-MAIL: HAWS@HAWS.CO.COM WEBSITE: WWW.HAWS.CO.COM	
				ECN NO: 5081 DRAWN: MJ APPROVED: JL	REVISED PER BY: ECN: 5081 DATE: 06/08/16 DATE: 06/22/16
SCALE: 1:15		DRAWING TYPE: INSTALLATION		SIZE: A SHEET 1 OF 1	