

HALSEY TAYLOR OWNERS MANUAL

USES HFC-134A REFRIGERANT

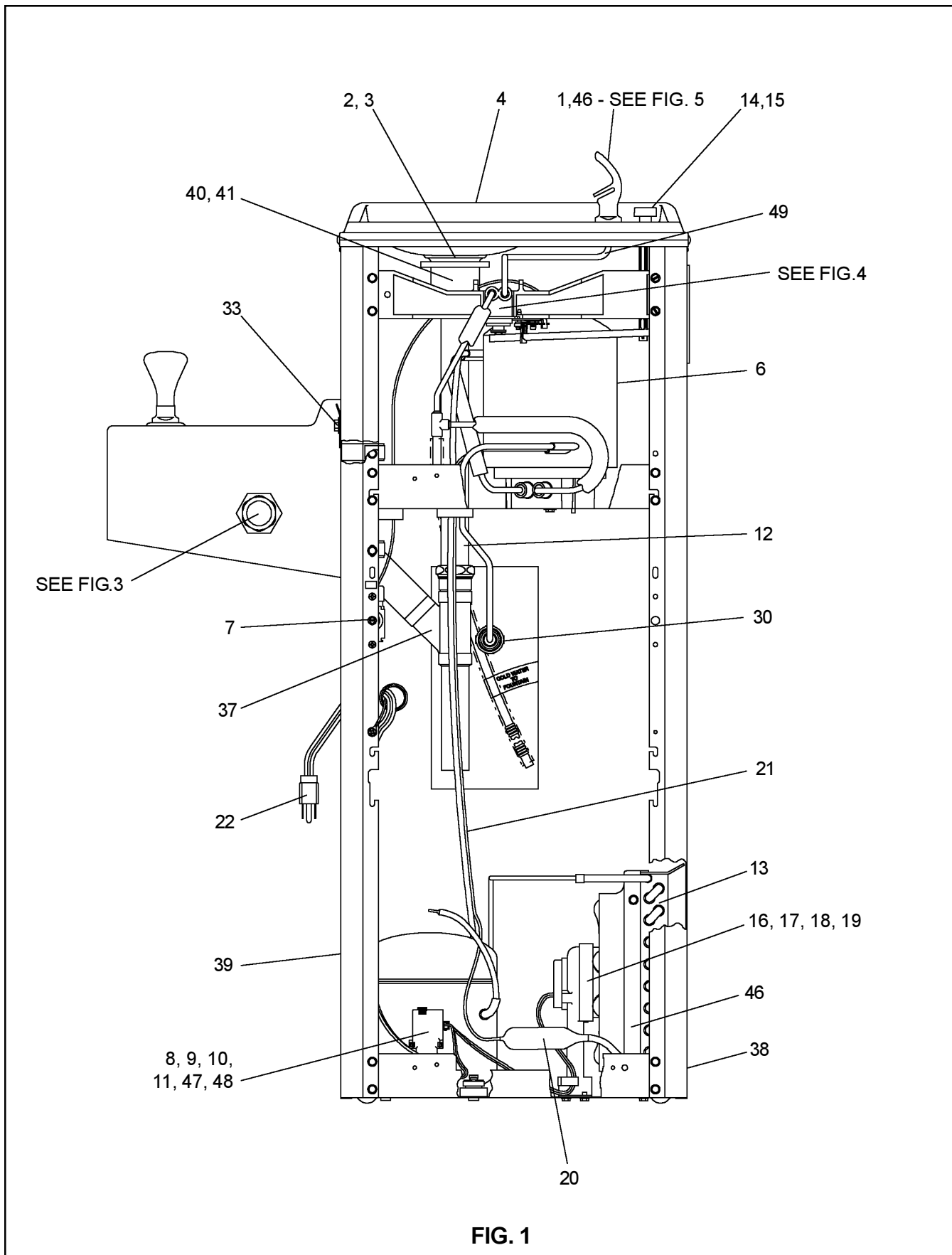

FIG. 1

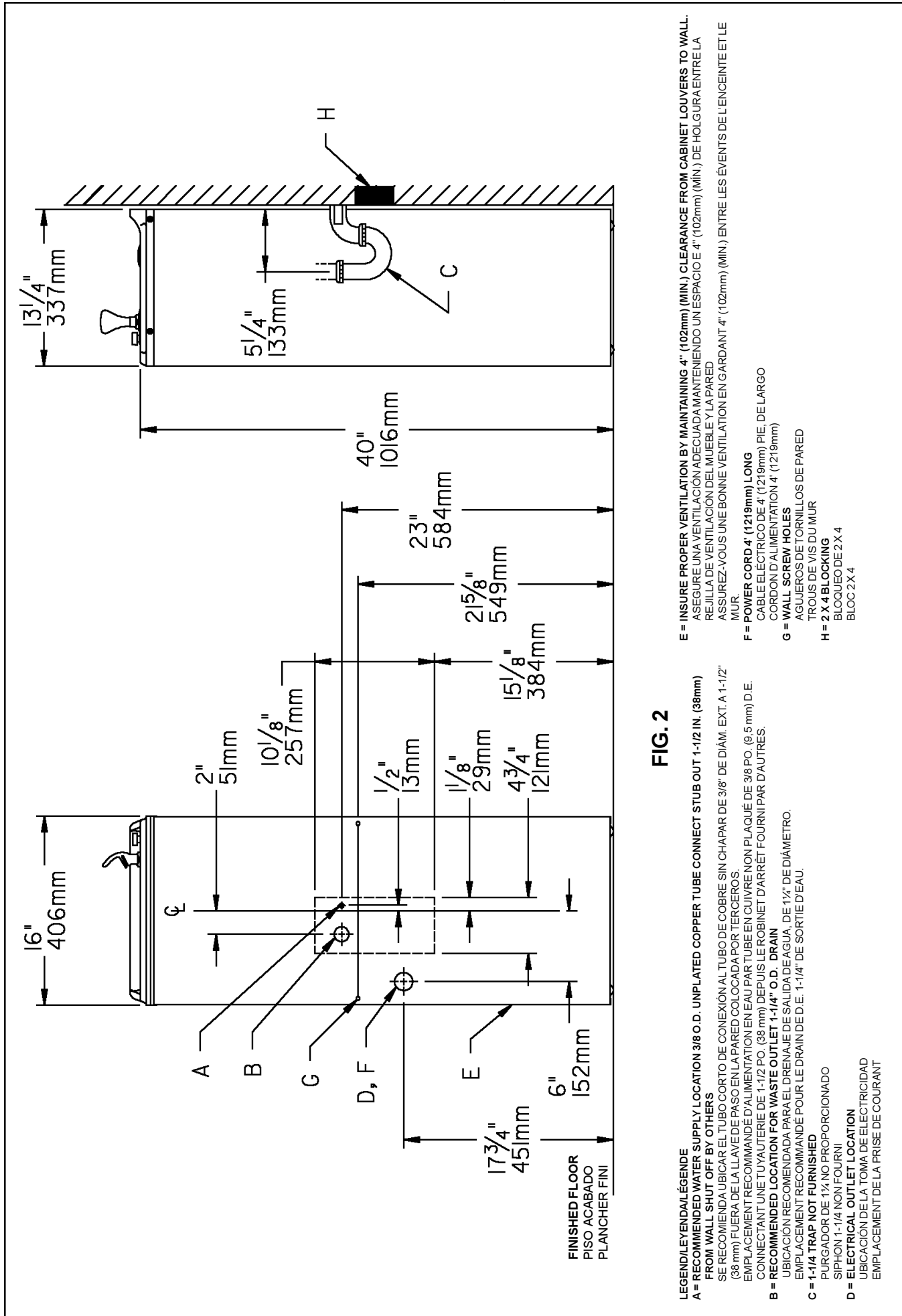

FIG. 2

LEGENDA/LEYENDA/LÉGENDE
A = RECOMMENDED WATER SUPPLY LOCATION 3/8" O.D. UNPLATED COPPER TUBE CONNECT STUB OUT 1-1/2 IN. (38mm)
 FROM WALL SHUT OFF BY OTHERS
 SE RECOMIENDA UBICAR EL TUBO CORTO DE CONEXIÓN AL TUBO DE COBRE SIN CHAPAR DE 3/8" DE DIAM. EXT. A 1-1/2" (38 mm) FUERA DE LA PARED COLOCADA POR TERCEROS.
 EMPLACEMENT RECOMMANDÉ D'ALIMENTATION EN EAUX PAR TUBE EN CUIVRE NON PLAQUÉ DE 3/8 PO. (9.5 mm) D.E. CONNECTANT UNE TUYAUTERIE DE 1-1/2 PO. (38 mm) DEPUIS LE ROBINET D'ARRÊT FOURNI PAR D'AUTRES.

B = RECOMMENDED LOCATION FOR WASTE OUTLET 1-1/4" O.D. DRAIN
 UBICACIÓN RECOMENDADA PARA EL DRENAJE DE SALIDA DE AGUA, DE 1 1/4" DE DIÁMETRO.
 EMPLACEMENT RECOMMANDÉ POUR LE DRAIN DE D.E. 1-1/4" DE SORTIE D'EAU.

C = 1-1/4" TRAP NOT FURNISHED
 PURGADOR DE 1 1/4" NO PROPORCIONADO
 SIPHON 1-1/4" NON FOURNI

D = ELECTRICAL OUTLET LOCATION
 UBICACIÓN DE LA TOMA DE ELECTRICIDAD
 EMPLACEMENT DE LA PRISE DE COURANT

E = INSURE PROPER VENTILATION BY MAINTAINING 4" (102mm) (MIN.) CLEARANCE FROM CABINET LOUVERS TO WALL.
 ASEGURE UNA VENTILACIÓN ADECUADA MANTENIENDO UN ESPACIO E 4" (102mm) (MIN.) DE HOLGURA ENTRE LA REJILLA DE VENTILACIÓN DEL MUEBLE Y LA PARED.
 ASSUREZ-VOUS UNE BONNE VENTILATION EN GARDANT 4" (102mm) (MIN.) ENTRE LES ÉVÉNENTS DE L'ENCEINTE ET LE MUR.

F = POWER CORD 4' (1219mm) LONG
 CABLE ELÉCTRICO DE 4' (1219mm) PIE DE LARGO
 CORDON D'ALIMENTATION 4' (1219mm)

G = WALL SCREW HOLES
 AGUEROS DE TORNILLOS DE PARED
 TROUS DE VIS DU MUR
H = 2 X 4 BLOCKING
 BLOQUEO DE 2 X 4
 BLOC 2 X 4

PUSH BUTTON VALVE ADJUSTMENT

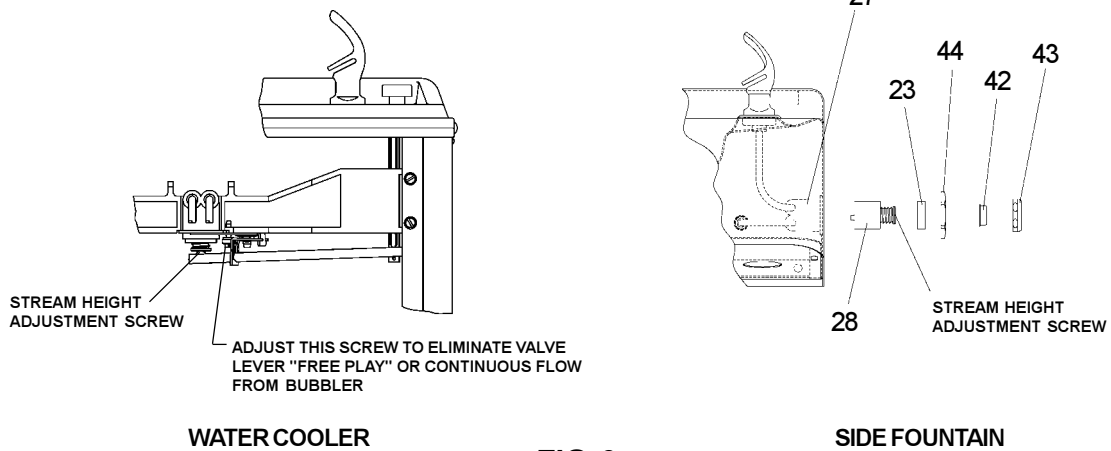

FIG. 3

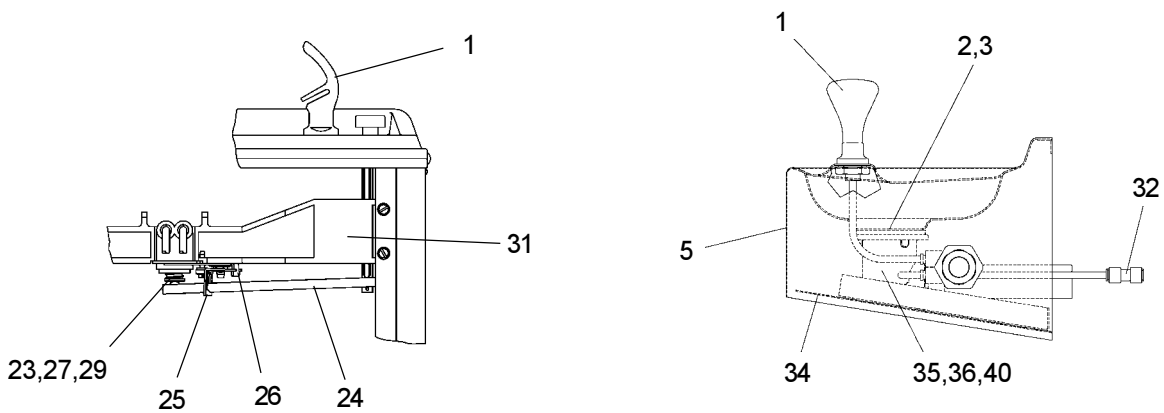
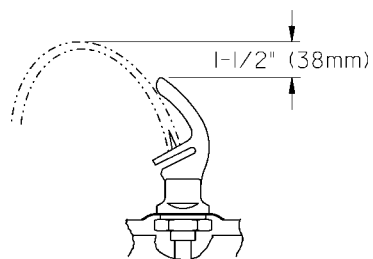

FIG. 4



CORRECT STREAM HEIGHT

FIG. 5

ITEMIZED PARTS LIST

ITEMNO.	PARTNO.	DESCRIPTION
1	51544C	Bubbler
2	102639931640	Drain Plug
3	160270508640	Strainer Plate
4	28346C	Basin (Cooler)
5	172613642830	Basin (Fountain)
6	66506C	Evaporator
7	31513C	Cold Control
*8	35775C	Compressor Serv. Pak
9	35840C	Overload
10	194243901550	Electrical Shield
11	35768C	Relay Cover
12	45698C	Tailpipe Assy
13	66252C	Condenser
14	101453431640	Cap Push Button
15	101507531550	Push Button Stem
16	31492C	Fan Motor
17	30664C	Fan Blade
18	70018C	Fan Blade Nut
19	402672043730	Fan Motor Bracket
20	66203C	Drier
21	66581C	Heat Exchanger
22	35887C	Power Cord
23	15005C	Regulator Retaining Nut
24	26860C	Regulator Lever
25	26861C	Pivot Bracket
26	26862C	Regulator Retaining Bracket
27	50986C	Regulator Holder
28	61313C	Regulator (Fountain)
29	61314C	Regulator (Cooler)
30	55996C	Strainer
31	55880C	Regulator Bracket
32	70745C	Union 3/8 x 1/4
33	401444343730	Hanger Bracket
34	400950543730	Cover Plate
35	55884C	Drain Elbow
36	66345C	Waste Tube
37	601502051550	Drain Assy
38	See Color Table	Side Panel - Right
39	See Color Table	Side Panel - Left
40	75588C	Nut - Slip Joint 1-1/4
41	55913C	Adaptor - Drain
42	40048C	Button
43	40089C	Cover Nut
44	40169C	Hex Nut
45	15008C	Nipple - Bubbler
46	101452831560	Fan - Shroud
47	35843C	Relay
48	35844C	Capacitor
49	56092C	Poly Tubing (Cut To Length)
NS	See Color Table	Front Panel

*INCLUDES RELAY & OVERLOAD. IF UNDER WARRANTY, REPLACE WITH SAME COMPRESSOR USED IN ORIGINAL ASSEMBLY.

NOTE: All correspondence pertaining to any of the above water coolers or orders for repair parts MUST include Model No. and Serial No. of cooler, name and part number of replacement part.

COLOR	RIGHT PANEL	LEFT PANEL	FRONT PANEL
Platinum (PV)	401536248410	401537548410	401507448410
Almond (AV)	26912C	26916C	26904C
Slate (SV)	401536248440	401537548440	401507448440
Stnlss Stl (SS)	401536242830	401537542830	401507442830

Halsley Taylor
 2222 CAMDEN COURT
 OAK BROOK, IL 60523
 630.574.3500

PRINTED IN U.S.A.

FOR PARTS, CONTACT YOUR LOCAL DISTRIBUTOR OR CALL 1.800.323.0620