

Halsey Taylor Owners Manual

Fully-Recessed Barrier-Free Water Cooler

RC

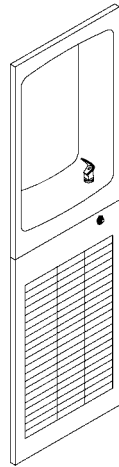

RC W/CUP DISPENSER

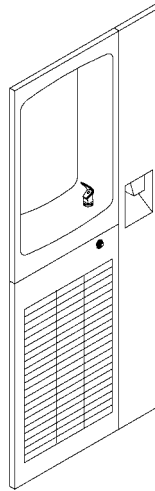

INSTALLER

To assure you install these models easily and correctly, PLEASE READ THESE SIMPLE INSTRUCTIONS BEFORE STARTING THE INSTALLATION. CHECK YOUR INSTALLATION FOR COMPLIANCE WITH PLUMBING, ELECTRICAL, AND OTHER APPLICABLE CODES. After installation, leave these instructions with the Water Cooler for future reference.

IMPORTANT

ALL SERVICE TO BE PERFORMED BY AN AUTHORIZED SERVICE PERSON

IMPORTANT! INSTALLER PLEASE NOTE.

THE GROUNDING OF ELECTRICAL EQUIPMENT SUCH AS TELEPHONE, COMPUTERS, ETC. TO WATER LINES IS A COMMON PROCEDURE. THIS GROUNDING MAY BE IN THE BUILDING OR MAY OCCUR AWAY FROM THE BUILDING. THIS GROUNDING CAN CAUSE ELECTRICAL FEEDBACK INTO A FOUNTAIN, CREATING AN ELECTROLYSIS WHICH CAUSES A METALLIC TASTE OR AN INCREASE IN THE METAL CONTENT OF THE WATER. THIS CONDITION IS AVOIDABLE BY USING THE PROPER MATERIALS AS INDICATED. ANY DRAIN FITTINGS PROVIDED BY THE INSTALLER SHOULD BE MADE OF PLASTIC TO ELECTRICALLY ISOLATE THE FOUNTAIN FROM THE BUILDING PLUMBING SYSTEM.

OPERATION OF QUICK CONNECT FITTINGS

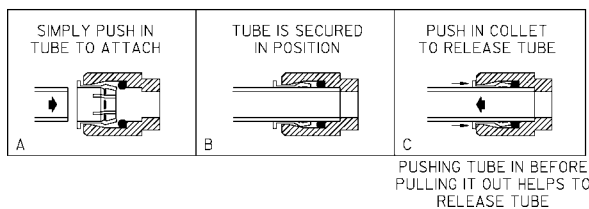

FIG. 1

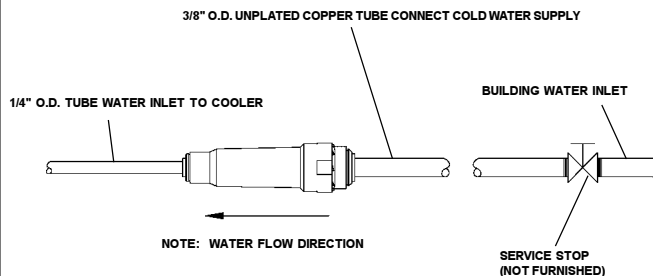

FIG. 2

**WALL FRAME INSTALLATION INSTRUCTIONS
FOR THE
RC MODELS DRINKING FOUNTAIN
(with and without cup dispenser)**

1. Cut a wall opening 24 7/8 W x 48 1/2 H (with cup dispenser), 17 1/8 W x 48 1/2 H (without cup dispenser). The bottom edge of the opening should be approx. 16 1/8" above the floor (See Fig. 3 with cup dispenser), (See Fig. 4 without cup dispenser). (check local codes for height requirement).
 2. After opening is completed, reinforce opening on all sides so that it may adequately support watercooler which weighs up to 150 lbs. and also provides a means of securing Wall Frame in place. (Install a wall stud indicated on Fig. 3 (with cup dispenser). NOTE: Building construction must allow for adequate airflow on both sides and top of chiller unit. 4" minimum required).
 3. Install rough plumbing to fountain. See Fig. 5 for location of supply water inlet to chiller and location of waste water outlet.
- *For cup dispenser model without glass filler plumbing, continue with step no. 5.
4. (Cup dispenser Models) Install rough plumbing to cup dispenser. See Fig. 13 for location of waste water outlet.
 5. Cut plastic ties holding chiller shelf support rods to framework.
 6. Install wall frame assembly in wall opening with front edge of frame flush with finished wall face. Secure frame through holes in top and sides to wall support members with 5/16" diameter fasteners (bolts or lag screws) as required by wall constructions. (14) bolts/screws required. CAUTION: DO NOT USE LESS THAN REQUIRED QUANTITY AND SIZE (DIAMETER) OF FASTENERS.
 7. Install chiller shelf. Place shelf on lower frame member and attach support rods. Secure front edge of the frame and wall construction using two 5/16" diameter lag screws or bolts. Tighten securely.
 8. Install electrical conduit. Fig. 5 shows electrical conduit connection location.
 9. Now you are ready to install fountains

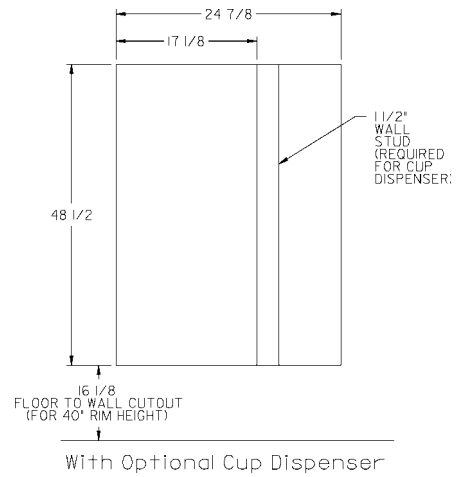

FIG. 3

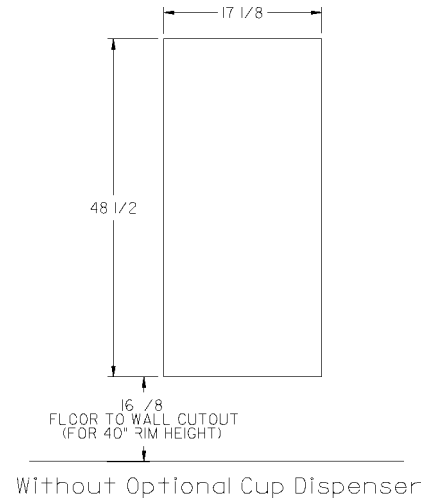

FIG. 4

PLUMBING ROUGH-IN

* NOTE If wall opening height has been adjusted to meet local codes (see Step No. 1 of installation instructions), height dimensions must be adjusted accordingly.

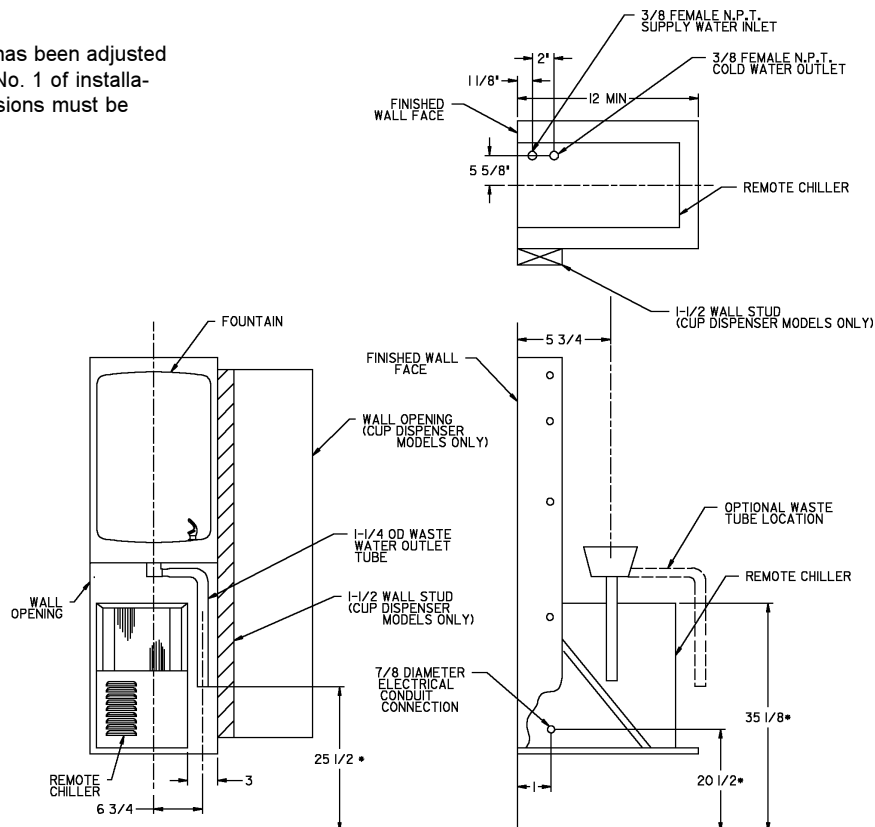

FIG. 5

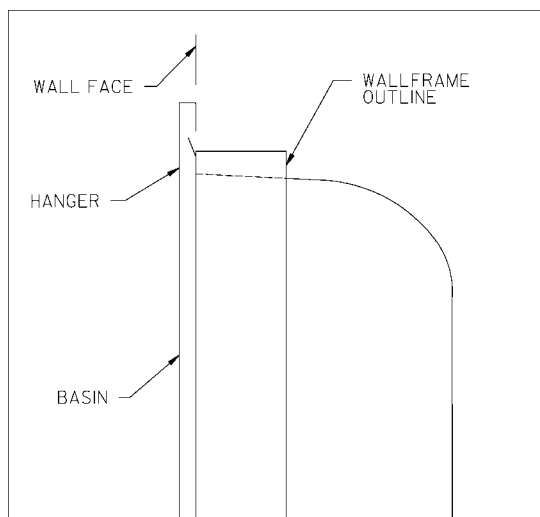

FIG. 6

INSTALLATION INSTRUCTIONS FOR THE RC MODELS DRINKING FOUNTAIN (refrigerated and non-refrigerated)

1. Familiarize yourself with the RC Wallframe which should already be in place in the wall. If not, refer to the "RC Wallframe" Installation Instructions before proceeding.
2. Determine location of rough plumbing. At this point, you should decide which style trap you plan to use. For easier installation, we recommend the use of a swivel trap.
3. Install the basin (See Fig. 6). Hold the basin flush against the wall, positioning the top edge just above the upper edge of the wallframe. Then slide the basin down slowly until it engages the hanger bracket. Be sure the basin is firmly engaged before releasing it.
4. Finish securing basin in place. Align the brackets at the bottom of the basin with the bracket on the frame. Fasten the brackets together using screws and speednuts (provided with fountain).
5. Install tailpiece assembly. Slide the slip nut and gasket from the trap onto the tailpiece. Insert the tailpiece assembly into the trap and align its other end with the drain hole in the basin. Place rubber gasket between the tailpiece assembly and the basin, then screw in the drain plug from above. Tighten the drain plug. Tighten slip nut and swivel joint. Snap the strainer plate into the drain plug.
6. Install a service stop (not provided) on the supply water inlet line. Turn on supply water and flush thoroughly.
7. Install refrigeration unit. Slide refrigeration unit into the wallframe and position tight against left side and flush with the front edge of wallframe. **WARNING:** Adequate space must be maintained behind the refrigeration unit for air circulation.
8. Water supply connections (See Fig 7 & 8)
 - A. RC8A Models – Connect service stop to tube marked "Water Inlet" on remote chiller. Make connection from chiller "Cold Water Outlet" tube to regulator valve assembly using the provided elbow and strainer.
 - B. RC12A Models – Connect service stop to precooler/tailpiece assembly inlet tube. Connect precooler/tailpiece assembly outlet tube to tube marked "Water Inlet" on remote chiller. Make connection from chiller "Cold Water Outlet" tube to regulator valve assembly using the provided elbow and strainer.
9. GF Model Only. Connect glass filler line to outlet on tee located between strainer and regulator valve assembly. (See Fig. 7A & 8A)
10. Open service stop and operate push button to purge air. Check thoroughly for leaks.
11. Check stream height from bubbler. Stream height is factory set at 45 – 50 PSI. If supply pressure varies greatly from this, remove items 17 & 18 and adjust screw on regulator (item 14). Clockwise adjustment will raise stream height and CCW adjustment will lower stream height. For best adjustment, stream height should be approximately 1-1/2" (38mm) above the bubbler guard. (See Fig. 15)
12. Connect refrigeration unit to electrical supply and check for proper operation. **WARNING:** Adequate space must be maintained behind the refrigeration unit for air circulation.
13. Attach regulator holder (item 13) to grill (item 3) with hex nut (item 16). Hold grill and engage angle on top edge of grill with lower edge of basin. Swing bottom of grill into place against the wall and securing grill mounting screws (provided).

WATER SUPPLY CONNECTIONS RC8A/8AGF MODELS

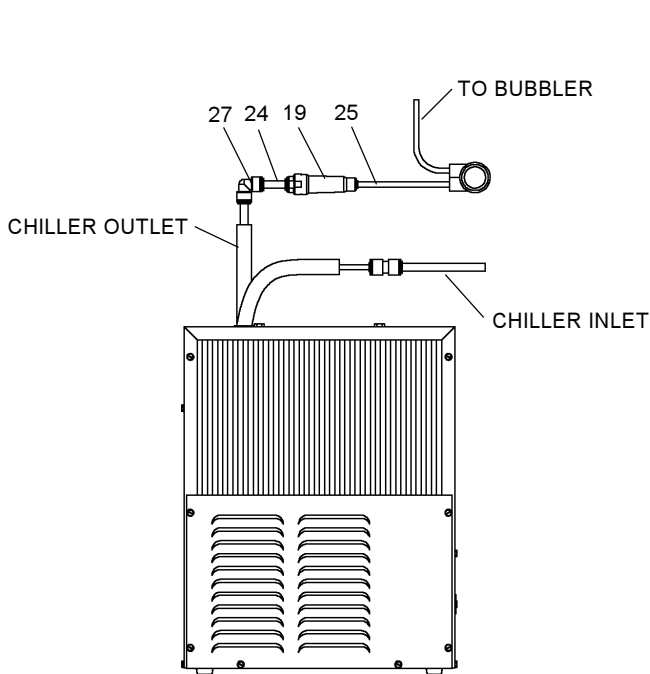

FIG. 7

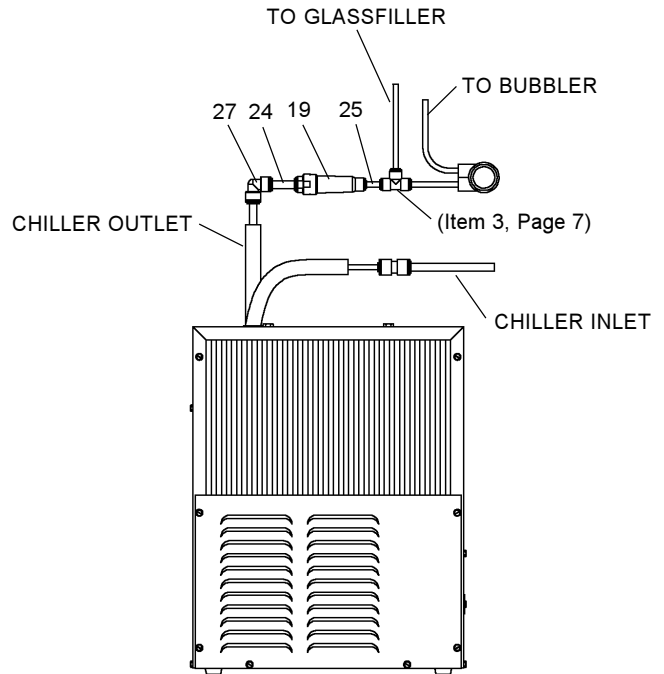

FIG. 7A

WATER SUPPLY CONNECTIONS RC12A/12AGF MODELS

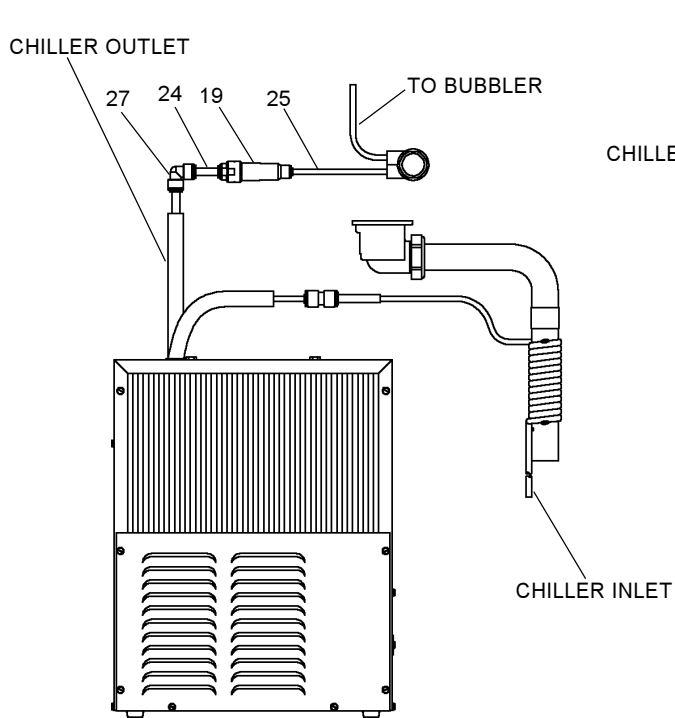

FIG. 8

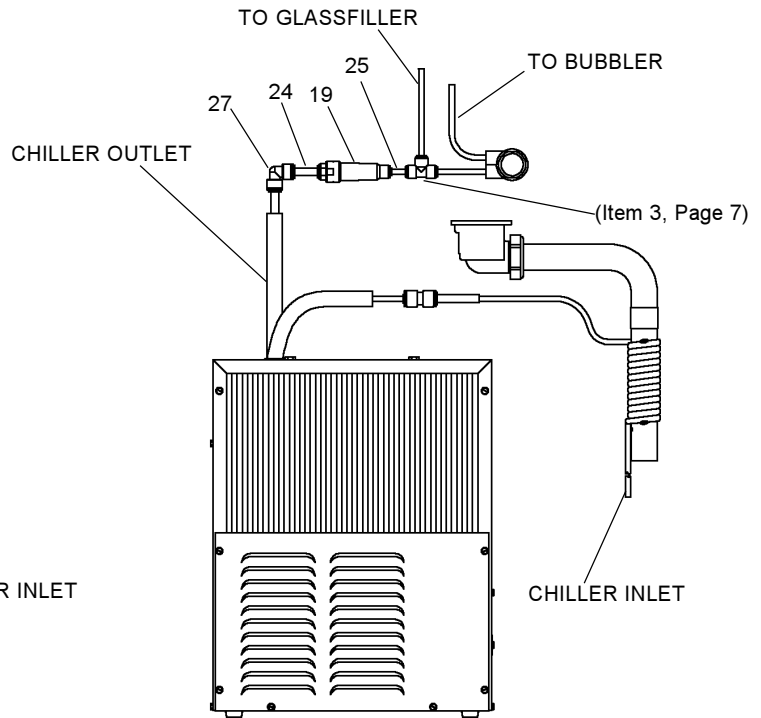

FIG. 8A

**INSTALLATION INSTRUCTIONS
FOR THE
RC CUP DISPENSER OPTION
MODELS: 14762**

1. Open door of cup dispenser and remove waste bin.
2. Shim along the bottom and side of cup dispenser as required to obtain a good alignment with previously installed drinking fountain. Be sure to check for proper operation of access door before securing unit in place. Securing can be done through slots provided using screws or bolts (as required by wall construction).
3. Replace waste bin.

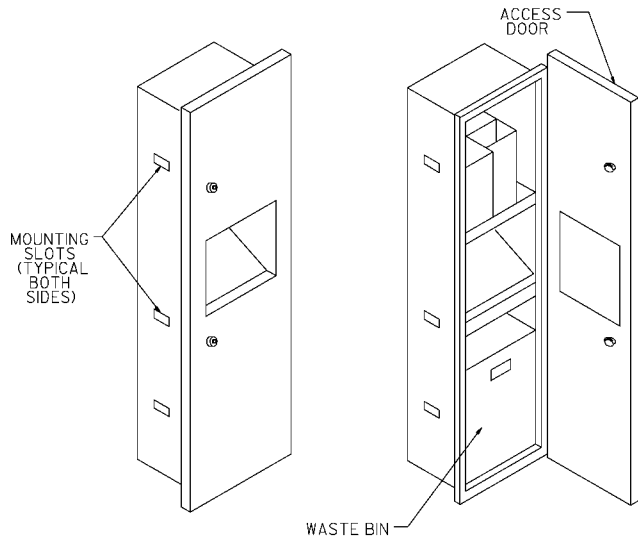

FIG. 9

**PLUMBING ROUGH-IN
CUP DISPENSER WITH GLASS FILLER**

* NOTE If wall opening height has been adjusted to meet local codes (see Step No. 1 of installation instructions), height dimensions must be adjusted accordingly.

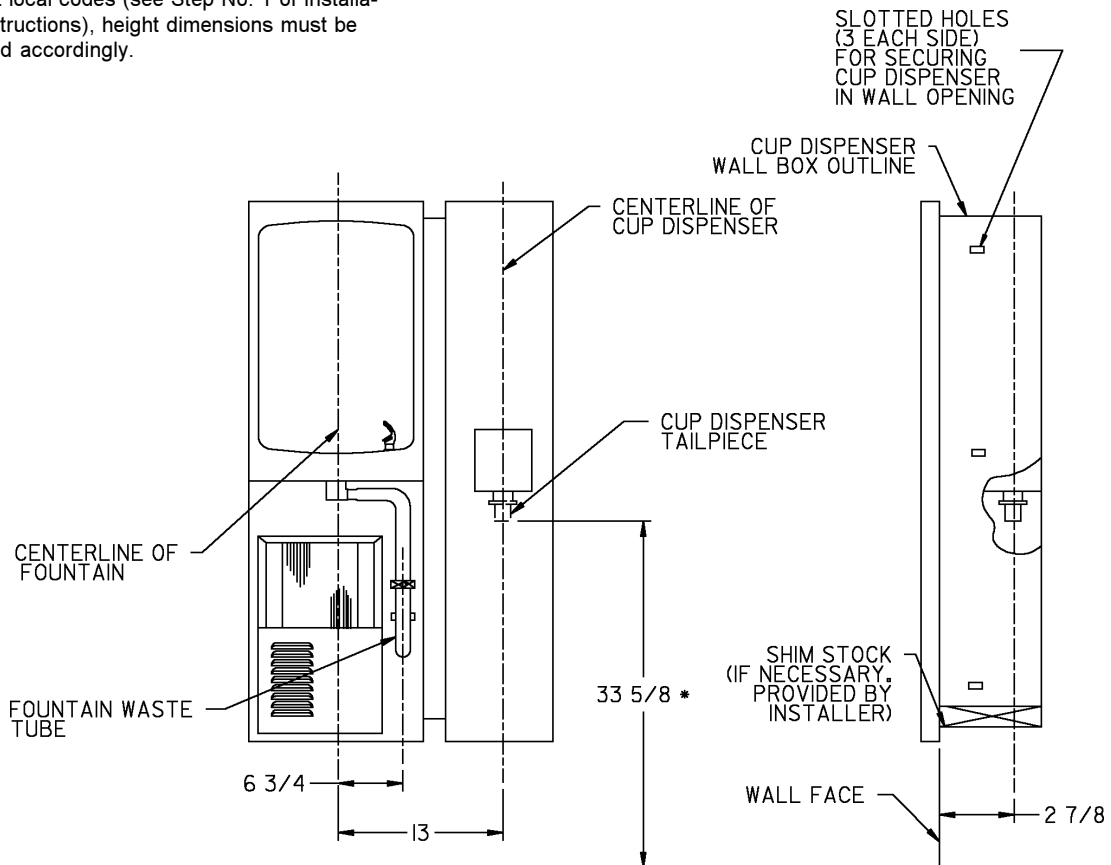

FIG. 10

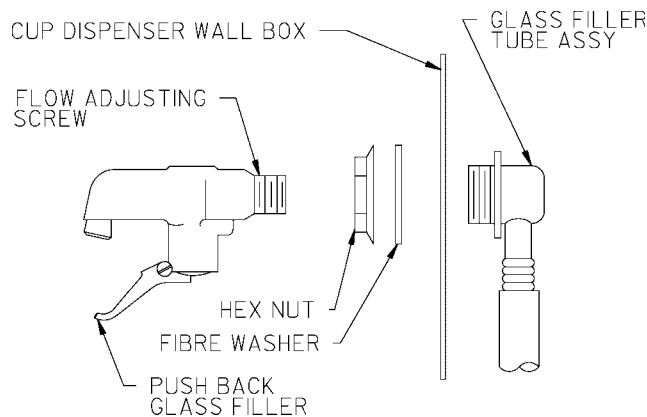

FIG. 11

INSTALLATION INSTRUCTIONS
 FOR THE
RC MODEL DRINKING FOUNTAIN
 (with optional cup dispenser)

1. The 14700 Model Cup Dispenser with Glassfiller is designed to complement model RCA3 drinking fountains. The fountain should already be installed before beginning installation, if not, refer to page 2 for your model. Remove louvered access panel from fountain via the two screws at the bottom.
2. Check wall opening to see if provisions have been made to accept this cup dispenser. If they have not, refer to page 2 for rough-in instructions. CAUTION: Wall construction must be framed to support fountain and cup dispenser (approximately 150 pounds).
3. See Parts List Illustration (page 7) for exact location of cup dispenser tailpiece. Decide which style of waste trap you intend to use. For easier installation, we recommend the use of a swivel trap.
4. Orientate yourself to the configuration of the cup dispenser. Open front door and remove the spring loaded trash access panel. To remove access panel, just loosen the four mounting screws and pull out the panel. Also remove the waste bin. Note location of mounting slots in the wall box portion of the cup dispenser. The slots are for affixing wallbox to building construction.
5. Put cup dispenser in wall opening. Determine shimming required to obtain a good alignment with fountain. Open and close door to ensure proper operation. CAUTION: Do not "suspend" cup dispenser via the mounting slots - be sure to shim along bottom edge to bear the weight of the cup dispenser.
6. Secure cup dispenser in place. Use lag screws or bolts as required by wall construction.
7. Install glass filler supply tube assembly. (Figure 11). Put glass filler fitting through hole provided in back, put fibre washer on from the front and screw on the hexagonal mounting nut. Note that the tubing itself is flex-tubing which will enable you to hand-form as required for installation.
8. Install glass filler. First remove the blue handle, then screw the glass filler into the glass filler fitting. Reattach blue handle.
9. Turn off supply water to the RCA-3 drinking fountain. Disconnect supply tubing from fitting located at the push button valve assembly. Remove elbow from valve assembly and install tube tee (provided). Reconnect supply water tubing (see parts list illustration on page 7).
10. Connect glass filler supply tubing to tee.
11. Install tailpiece assembly (as shown in Figure 12). Connect waste trap (not provided).
12. Turn on supply water and operate push button valve and glass filler. Check entire system for leaks. Water flow from the glass filler can be adjusted by turning the flow adjusting screw (see Figure 11). In order to adjust, it may be necessary to remove, and then reinstall the glass filler, per step 8 above.
13. Replace the spring loaded trash access panel via the four mounting screws. Reinstall louvered grill on the RCA-3 fountain.

RC8°C RC12°C AND 14762 & 14700 CUP DISPENSER

ITEMIZED PARTS LIST

ITEM NO.	PART NO.	DESCRIPTION
1	101470051830	Disp - Cup w/GF Provisions
2	160807751640	Assy - Valve Push Back
3	161563108550	Tee - 3/8t x 3/8t x 1/4 NPT
4	601565851550	GF Tube for 14700 Disp
5	411564208650	Nut - Hex
6	100115824740	Washer - Fibre
7	100147140560	Gasket - Drain
8	100352940560	Gasket - Slip Nut
9	110346220550	Nut - Hex
10	160270508640	Strainer - Plate
11	160346008640	Tailpipe 1-1/4 x 4
12	160346308640	Nut - Slip 1-1/2
13	161637308640	Plug - Drain 1-1/2

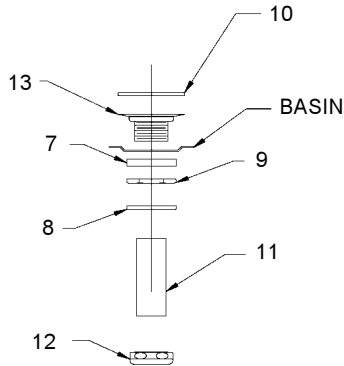

FIG. 12

IMPORTANT: Fountain and glassfiller are rated for a supply pressure of 90 PSI minimum. If supply pressure exceeds this, a pressure reducing regulator should be installed on the supply line. Minimum supply pressure - 15 PSI.

PLUMBING ROUGH-IN
CUP DISPENSER WITH GLASS FILLER

* NOTE If wall opening height has been adjusted to meet local codes (see Step No. 1 of installation instructions), height dimensions must be adjusted accordingly.

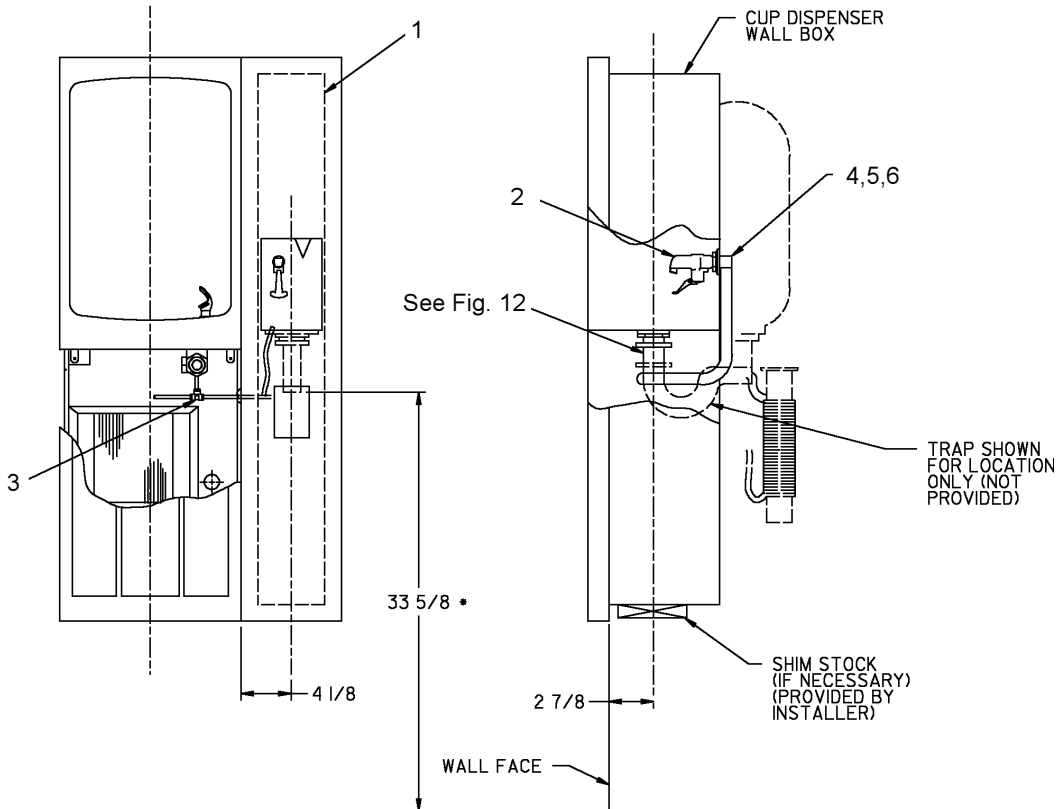

FIG. 13

RC8°C RC12°C AND 14762 & 14700 CUP DISPENSER

ITEMIZED PARTS LIST

ITEM NO.	PART NO.	DESCRIPTION
1	170857042830	Basin
	27673C	Basin – Aztec Gold
2	732660951550	Mounting Frame
3	23040C	Grill
	27671C	Grill – Aztec Gold
4	Reference	Remote Chiller Assembly
5	100147140560	Gasket
6	160270508640	Strainer Plate – Chrome
	45400C	Strainer Plate – Aztec Gold
7	161637308640	Drain Plug - Chrome
	45398C	Drain Plug – Aztec Gold
8	51546C	Bubbler – Chrome
	45396C	Bubbler – Aztec Gold
9	100322740560	Gasket – Bubbler (2-Req'd)
10	10080C	Nipple – Bubbler
11	66347C	Tube – Waste RC8
	45440C	Waste Line/Precooler Assy-RC12
12	74050011	Sound Dampening Pad (NS)
13	50986C	Holder – Regulator
14	61313C	Regulator
15	15005C	Retaining Nut
16	40169C	Hex Nut – Chrome
	45427C	Hex Nut – Aztec Gold
17	40048C	Button – Chrome
	45419C	Button – Aztec Gold
18	40089C	Cover Nut – Chrome
	45422C	Cover Nut – Aztec Gold
19	55996C	Strainer
20	1110166	Screw - #8 x 3/4" Type AB
21	55884C	Elbow – Drain
22	75588C	Nut - Slip Joint 1-1/4
23	100147140560	Gasket - Drain
24	62223C	Tube - Cu. 3/8 x 4.75
25	62257C	Tube - Cu. Regulator In
26	62300C	Tube Assy - Bubbler 8880
27	70896C	Fitting - Elbow

TROUBLE SHOOTING AND MAINTENANCE

CAUTION: Cleaning of Aztec Gold Models requires special care. Outer surfaces must be cleaned with a mild detergent or mixture of vinegar and water only, rinsed and wiped dry. Abrasive and acidic cleaners may eventually damage the Aztec Gold finish.

Orifice Assy: Mineral deposits on orifice can cause water flow to spurt or not regulate. Mineral deposits may be removed from the orifice with a small round file not over 1/8" diameter or small diameter wire. **CAUTION: DO NOT** file or cut orifice material.

Stream Regulator: If orifice is clean, regulate flow as in instructions. If replacement is necessary, see parts list for correct regulator part number.

Actuation of Quick Connect Water Fittings: Cooler is provided with lead-free connectors which utilize an o-ring water seal. To remove tubing from the fitting, relieve water pressure, push in on the gray collar while pulling on the tubing.(see Fig.1) To insert tubing, push tube straight into fitting until it reaches a positive stop, approximately 3/4".

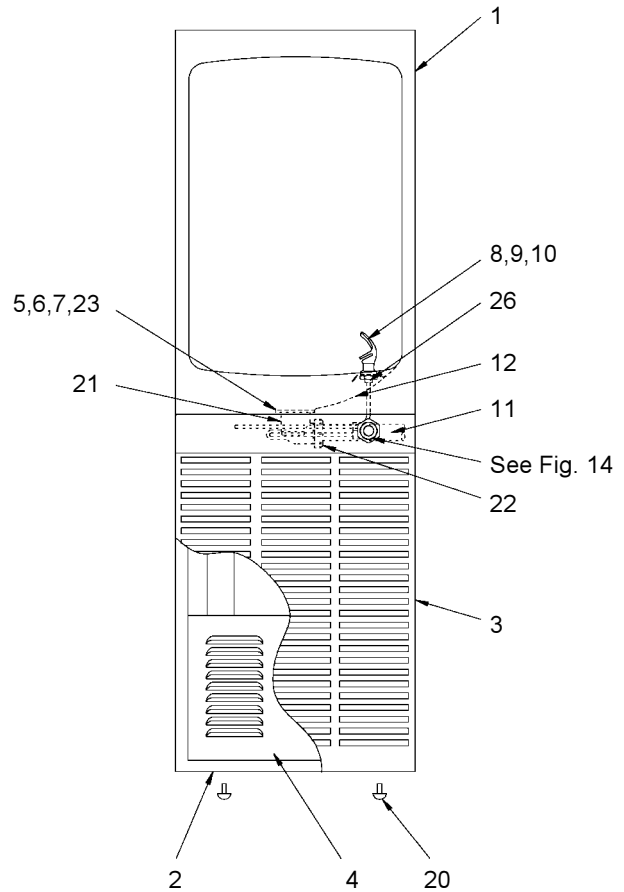
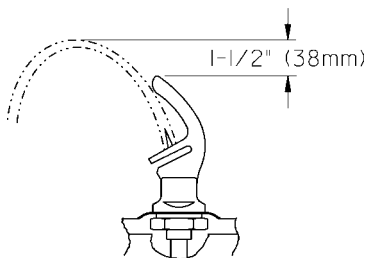
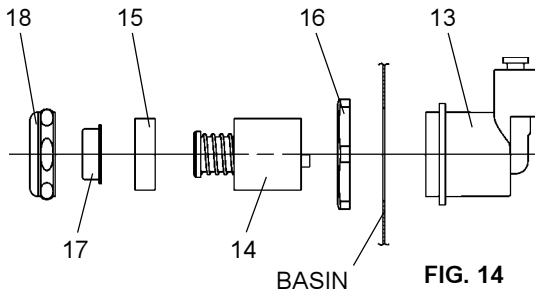

CORRECT STREAM HEIGHT

FIG. 15

Halsey Taylor
 2222 CAMDEN COURT
 OAK BROOK, IL 60523
 630.574.3500

PRINTED IN U.S.A.

FOR PARTS, CONTACT YOUR LOCAL DISTRIBUTOR OR CALL 1.800.323.0620