

HALSEY TAYLOR OWNERS MANUAL

OVL-II™ Series Electronic Eye Barrier-Free Water Coolers Refrigerated Fountains with Back Panel



Fig.1 – OVL-II-EREE-Q



Fig. 2 – OVL-II-SREE-Q



Fig. 3 – OVL-II-SEREE-Q



Fig. 4 – OVL-II-ESREE-Q

Figure	Model	Description
1	OVL-II-EREE-Q	OVL-II Series - Extended Reach
2	OVL-II-SREE-Q	OVL-II Series - Standard Reach
3	OVL-II-SEREE-Q	OVL-II Series - Dual Installation
4	OVL-II-ESREE-Q	OVL-II Series - Dual Installation

INSTALLER



CAUTION:

Review these instructions before beginning installation. Be sure that installation conforms to all plumbing, electrical and other applicable codes.



WARNING:

When installation is complete, ensure these instructions are left in the plastic bag provided inside the installed unit for future reference.



WARNING:

Service to be performed by authorized service personnel only.

NOTE: It is common practice to ground electrical hardware such as telephones, computers and other devices to available water lines. This can, however, cause electrical feedback in the plumbing circuit, which results in an “electrolysis” effect occurring in the fountain. This may result in water which has a metallic taste to it or has a noticeable increase in the metallic content of the water.

When inspecting plumbing circuit, remember the line may be grounded some distance from the installation, and may occur outside the building or area in which the unit is being installed.

This condition can be avoided (in most cases) by using recommended materials during installation. Any drain fittings provided by the installer should be made of **plastic** which will electronically isolate the fountain from the remainder of the building’s plumbing circuits.

Installation Package

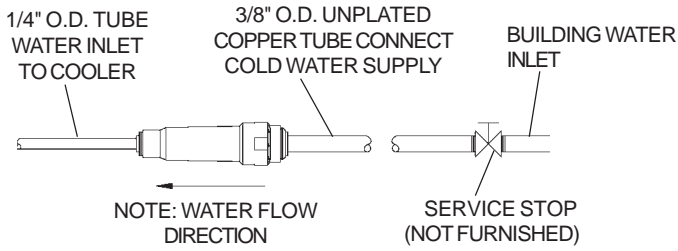

Figure 5 – Water Supply Connections

The components for installation are packed in three separate boxes, regardless of the type of unit being installed. The boxes contain the following:

- Box No. 1: Wall Frame(s)
- Box No. 2: Remote Chiller, SJ8-Q
- Box No. 3: Fountain(s), Arm(s) and Panels

Additional materials, as noted in the Parts List, are also shipped in these boxes.

Parts List **Number Required**

Item	Part No.	Description	OVL-II EREE-Q	OVL-II SREE-Q	OVL-II SEREE-Q	OVL-II ESREE-Q	See Fig.
1	27688C	Bottom Cover - Standard Reach (EE)	-	1	-	-	25
	27689C	Bottom Cover - Extended Reach (EE)	1	-	1	1	25
	26990C	Bottom Cover - Standard Reach	-	-	1	1	23
2	55836C	Push Arm Actuator	-	-	1	1	20
	55991C	Push Arm Actuator - A.G.	-	-	1	1	20
3	51546C	Bubbler - S.S.	1	1	2	2	24, 27
	45396C	Bubbler - A.G.	1	1	2	2	24, 27
	55905C	Bubbler - EasyFlex (option)	1	1	2	2	24, 27
4	100322740560	Bubbler Gasket	2	2	4	4	24, 27
5	160270508640	Strainer Plate - S.S.	1	1	2	2	24, 27
	45400C	Strainer Plate - A.G.	1	1	2	2	24, 27
6	101570540560	Drain Gasket	1	1	2	2	24, 27
7	51575C	Packing Ring	1	1	2	2	24, 27
8	110346220550	Drain Nut	2	2	4	4	24, 27
9	101637451550	Friction Ring	1	1	2	2	24, 27
10	161637308640	Drain Plug - S.S.	1	1	2	2	24, 27
	45398C	Drain Plug - A.G.	1	-	2	2	24, 27
11	45682C	Drain Tube	-	1	1	1	24, 27
	45683C	Drain Tube	1	-	1	1	24, 27
12	100023340560	Waste Tube Gasket	1	1	2	2	24, 27
13	161570808550	Slip Nut	1	1	2	2	24, 27
14	61313C	Regulator - W/Red Spring	1	1	1	1	27
	61314C	Regulator - W/Green Spring	-	-	1	1	22
15	50986C	Regulator Holder	1	1	2	2	22, 27
16	27006C	Basin - S.S.	1	1	2	2	24
	27342C	Basin - A.G.	1	1	2	2	24
17	27000C	Basin Liner - S.S.	1	1	2	2	24
	27344C	Basin Liner - A.G.	1	1	2	2	24
18	38417001	Screw - #8-18 x .37	2	2	2	2	7, 10
19	55840C	Top Plate - Actuator	-	-	1	1	20
20	55839C	Bottom Plate - Actuator	-	-	1	1	20
21	27691C	Extended Reach Arm (EE) - S.S.	1	-	1	1	25
	27754C	Extended Reach Arm (EE) - A.G.	1	-	1	1	25
	27692C	Standard Reach Arm (EE) - S.S.	-	1	-	-	25
	27755C	Standard Reach Arm (EE) - A.G.	-	1	-	-	25
22	27004C	Standard Reach Arm - S.S.	-	-	1	1	24
	27340C	Standard Reach Arm - A.G.	-	-	1	1	24
23	28328C	Regulator Mounting Bracket	-	-	1	1	21
24	15005C	Nut - Retaining	-	-	1	1	22

Parts List Continued

Item	Part No.	Description	OVL-II EREE-Q	OVL-II SREE-Q	OVL-II SEREE-Q	OVL-II ESREE-Q	See Fig.
25	27008C	Reaction Bracket	-	-	1	1	21
26	70856C	Screw - #10-24 x .38 PHMS	1	1	2	2	21
27	70854C	Rod - Pivot	-	-	1	1	21
28	50198C	Bushing Snap	-	-	4	4	21
29	51667C	Bumper - Regulator Valve Assy	-	-	1	1	21
30	28327C	Arm - Regulator Activating	-	-	1	1	21
31	28326C	Arm - Regulator Adjustment	-	-	1	1	21
32	22797C	Upper Panel (OVL-II EREE) - S.S.	1	-	-	-	13, 27
	27886C	Upper Panel (OVL-II EREE) - A.G.	1	-	-	-	13, 27
	22799C	Upper Panel (OVL-II SREE) - S.S.	-	1	-	-	13, 27
	27888C	Upper Panel (OVL-II SREE) - A.G.	-	1	-	-	13, 27
	26958C	Upper Panel (OVL-II SEREE) - S.S.	-	-	1	-	13, 24, 27
	27890C	Upper Panel (OVL-II SEREE) - A.G.	-	-	1	-	13, 24, 27
	22795C	Upper Panel (OVL-II ESREE) - S.S.	-	-	-	1	13, 24, 27
	27892C	Upper Panel (OVL-II ESREE) - A.G.	-	-	-	1	13, 24, 27
33	26833C	Lower Panel (OVL-II EREE/SREE) - S.S.	1	1	-	-	15, 27
	27894C	Lower Panel (OVL-II EREE/SREE) - A.G.	1	1	-	-	15, 27
	27026C	Lower Panel (OVL-II SEREE/ESREE) - S.S.	-	-	1	1	15, 24, 27
	27896C	Lower Panel (OVL-II SEREE/ESREE) - A.G.	-	-	1	1	15, 24, 27
34	55996C	Strainer (Supplied with Chiller)	1	1	1	1	17, 18
35	70683C	Union - 1/4"	1	1	-	-	17
36	70682C	Tee - 1/4"	-	-	1	1	18
37	56092C	Poly Tubing - 1/4" (Cut To Length)	1	1	1	1	17, 18
38	56159C	Bubbler Nipple Assembly	1	1	2	2	27
39	27687C	Regulator Mounting Bracket	1	1	1	1	25
40	31375C	Solenoid Valve Assy.	1	1	1	1	7, 10, 26
41	31376C	Power Cord	1	1	1	1	26
42	31384C	Sensor - Clear	1	1	1	1	25
43	40045C	Hex Nut - Unplated	1	1	2	2	22, 27
44	50203C	Strain Relief Bushing	1	1	1	1	25
45	50595C	Snap Bushing .50 I.D.	1	1	1	1	27
46	51409C	Spacer	2	2	2	2	25
47	56082C	Regulator Nut	1	1	1	1	27
48	70016C	Hex Nut - #10-32	2	2	2	2	25
49	70989C	Screw - #8-36 x .37 Ground	1	1	1	1	26
50	75507C	Fitting - 1/4 NPTF	2	2	2	2	26
51	70817C	Fitting - Elbow 1/4"	1	1	1	1	26

NOTE: S.S. means Stainless Steel

A.G. means Aztec Gold

Models OVL-II SEREE-Q – OVL-II ESREE-Q

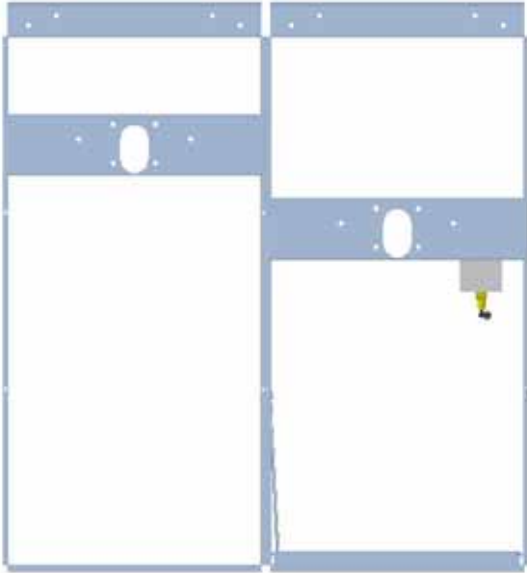
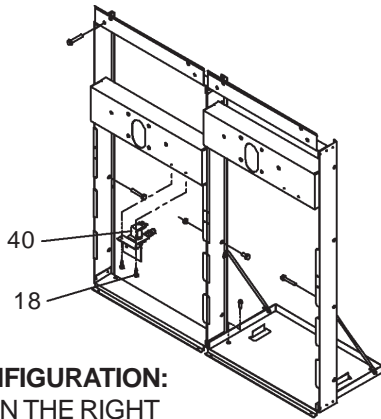

Figure 6 – OVL-II SEREE-Q Rough-In

1. **Cut a rectangular wall opening** 37-1/2" (953 mm) W x 37-3/4" H (959 mm) and 4-1/2" (114 mm) above the floor line (see Figure 7). The dimensions are required to obtain proper rim and bubbler heights for compliance with ANSI standard A117.1.
2. **Reinforce the wall opening** on all sides to adequately support the water fountain. This reinforcement must support up to 150 lbs. static load and provide a means for securing the frame assembly in place.
NOTE: Building construction must allow for adequate air flow on both sides and top of remote chiller unit a minimum of 4" (102 mm) is required.
3. **Install plumbing and electrical rough-ins.** A junction box for a (3) wire, 10 amp branch circuit is provided on the inside of the chiller. (Standard 120 Volts, 60 Hz, and single phase.)
4. **Remove frames and related hardware** from packaging. Release the two shelf rods by cutting cable ties. Attach the two frames together through the upright supports with (4) 5/16" x 3/4" (19 mm) long bolts and nuts (provided). Tighten securely.



**REVERSED CONFIGURATION:
HIGHER UNIT ON THE RIGHT**

5/16" SCREWS OR BOLTS
(12 REQ'D - NOT FURNISHED)

FRAME

5/16" HEX NUT
(4 REQ'D - PROVIDED)
P/N 111577343890

SCREWS OR BOLTS
(NUT PROVIDED)

INSTALL (3) SCREWS
(P/N 111008343890) IN FRAME
BEFORE INSTALLING IN OPENING

HOOK RODS (2)
P/N 101567443730

BOLT FRAMES TOGETHER
WITH 5/16" x 3/4" (19mm) BOLTS
(4 REQ'D - PROVIDED)
P/N 111577243890

**STANDARD CONFIGURATION:
HIGHER UNIT ON THE LEFT**

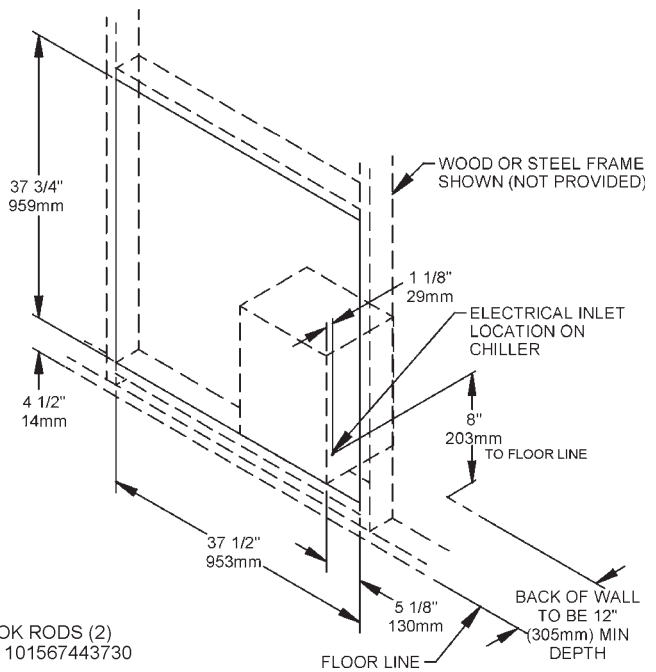

Figure 7 – Rough-In Assembly
Dual-Station Mounting Frames

5. **Install the frame assembly squarely in wall** opening with frame upright support edges flush with the finished wall face. Secure the frame to the wall through holes with (12) 5/16" bolts or screws (not provided). Tighten securely.

NOTE: Be sure that frame is squared in location. Do not use less than required screw quantity and size.

6. **Attach the chiller shelf support rods** to the right side of the frame uprights at the second set of holes counting from the bottom and to the shelf at the (2) side holes. Line up the other shelf holes with the frame bottom holes and fasten the assembly to the wall opening using appropriately sized screws or bolts and nuts (not provided).

MODEL OVL-SEREE SHOWN

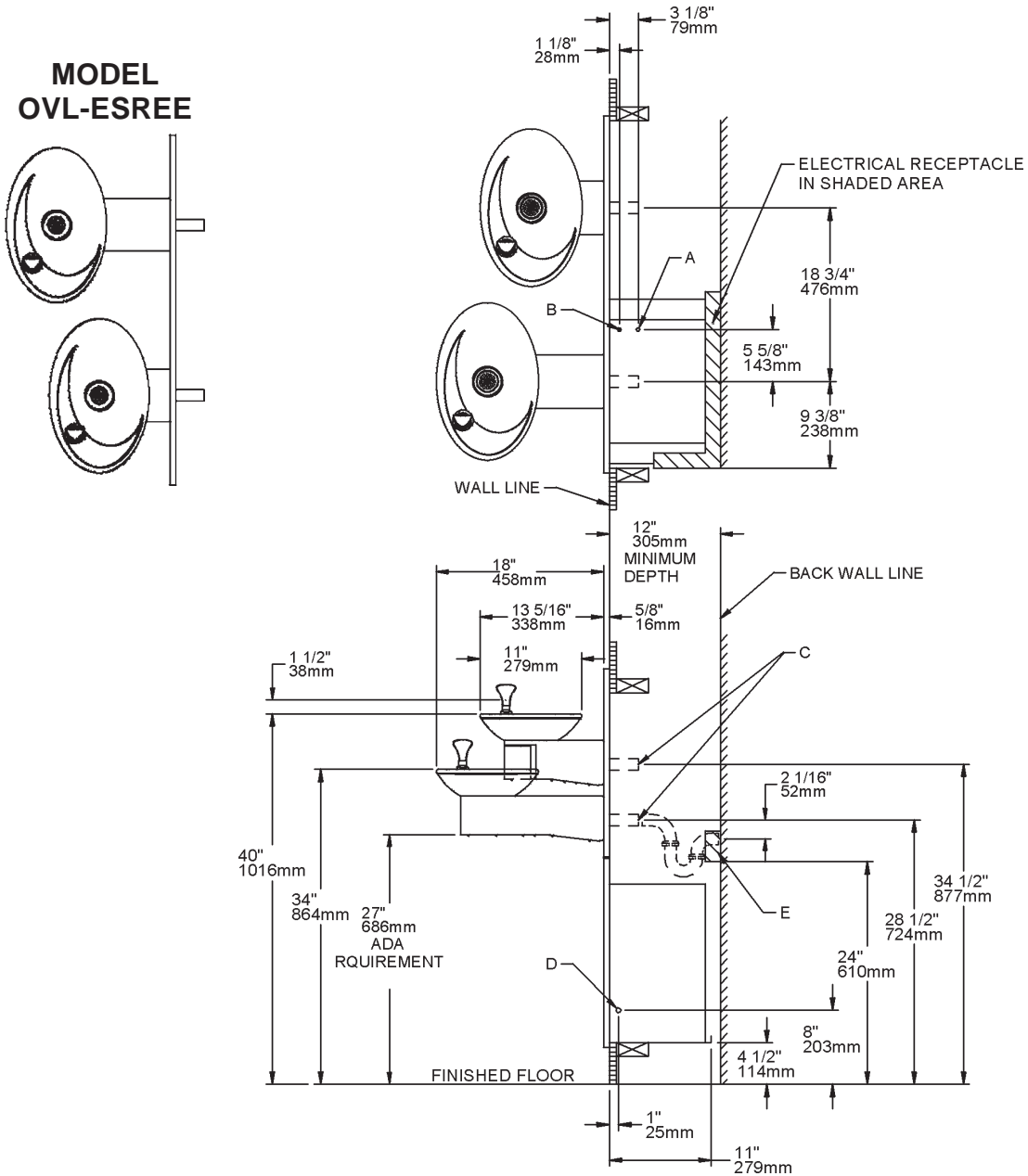

Legend

Item	Description
A	1/4" O.D. Tube - Water Outlet Connection
B	3/8" O.D. Tube - Water Inlet Connection
C	1-1/4" O.D. Waste Tube
D	Electrical Inlet on Chiller
E	Electrical Outlet Location. Additional UL/CSA listed grounded outlet (By others) required for 115 Volt, 60Hz.

Figure 8 – OVL-II SEREE-Q/OVL-II ESREE-Q Rough-In Dimensions

Models
OVL-II EREE-Q – OVL-II SREE-Q

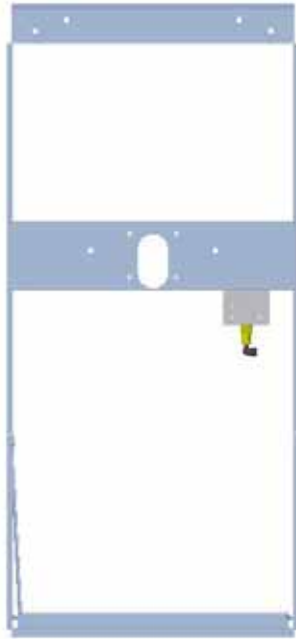

Figure 9 – OVL-II EREE-Q/OVL-II SREE-Q Rough-In

1. **Cut a rectangular wall opening** 18-3/4" (475 mm) W x 37-3/4" H (959 mm) and 4-1/2" (114 mm) above the floor line (see Figure 10). The dimensions are required to obtain proper rim and bubbler heights for compliance with ANSI standard A117.1.
2. **Reinforce the wall opening** on all sides to adequately support the water fountain. This reinforcement must support up to 150 lbs. static load and provide a means for securing the frame assembly in place.
NOTE: Building construction must allow for adequate air flow on both sides and top of remote chiller unit. Minimum of 4" (102 mm) is required.
3. **Install plumbing and electrical rough-ins.** A junction box for a (3) wire, 10 amp branch circuit is provided on the inside of the chiller. (Standard 120 Volts, 60 Hz, and single phase.)
4. **Remove frame and related hardware** from packaging. Release the two shelf rods by cutting cable ties.

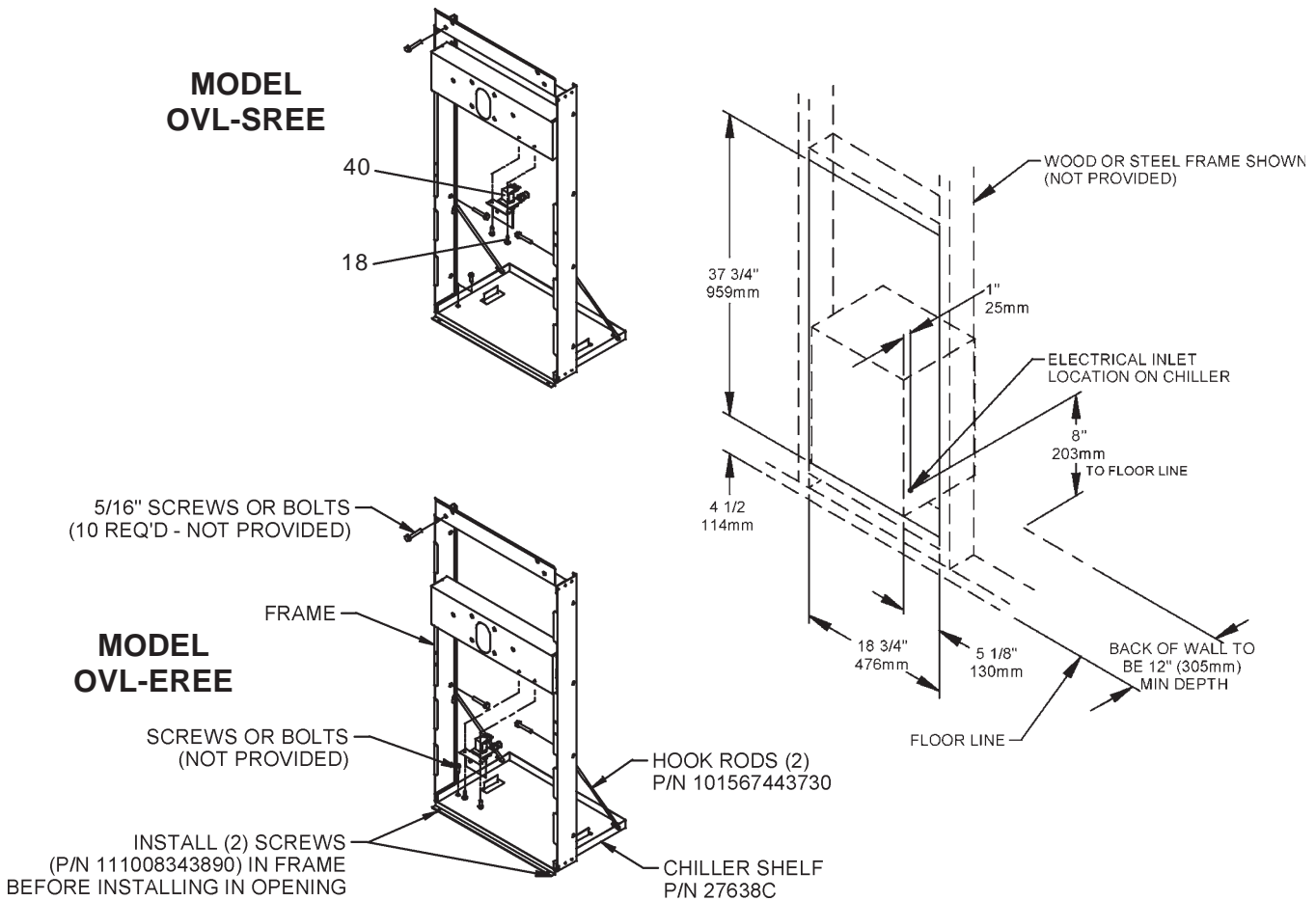

Figure 10 – Rough-In Assembly Single-Station Mounting Frames

5. **Install the frame squarely in wall** opening with frame upright edges flush with the finished wall surface. Place shelf inside frame and line up the (2) holes on each. Insert loose ends of rods into holes on sides of shelf panel. Using appropriately sized screws or bolts (not provided), fasten the shelf and frame to the bottom of wall opening.

Secure the frame sides and top to the wall opening using (10) 5/16" bolts or screws (not provided).

NOTE: Be sure that frame is squared in location. Do not use less than the required screw quantity and size.

MODEL OVL-EREE

MODEL OVL-SREE

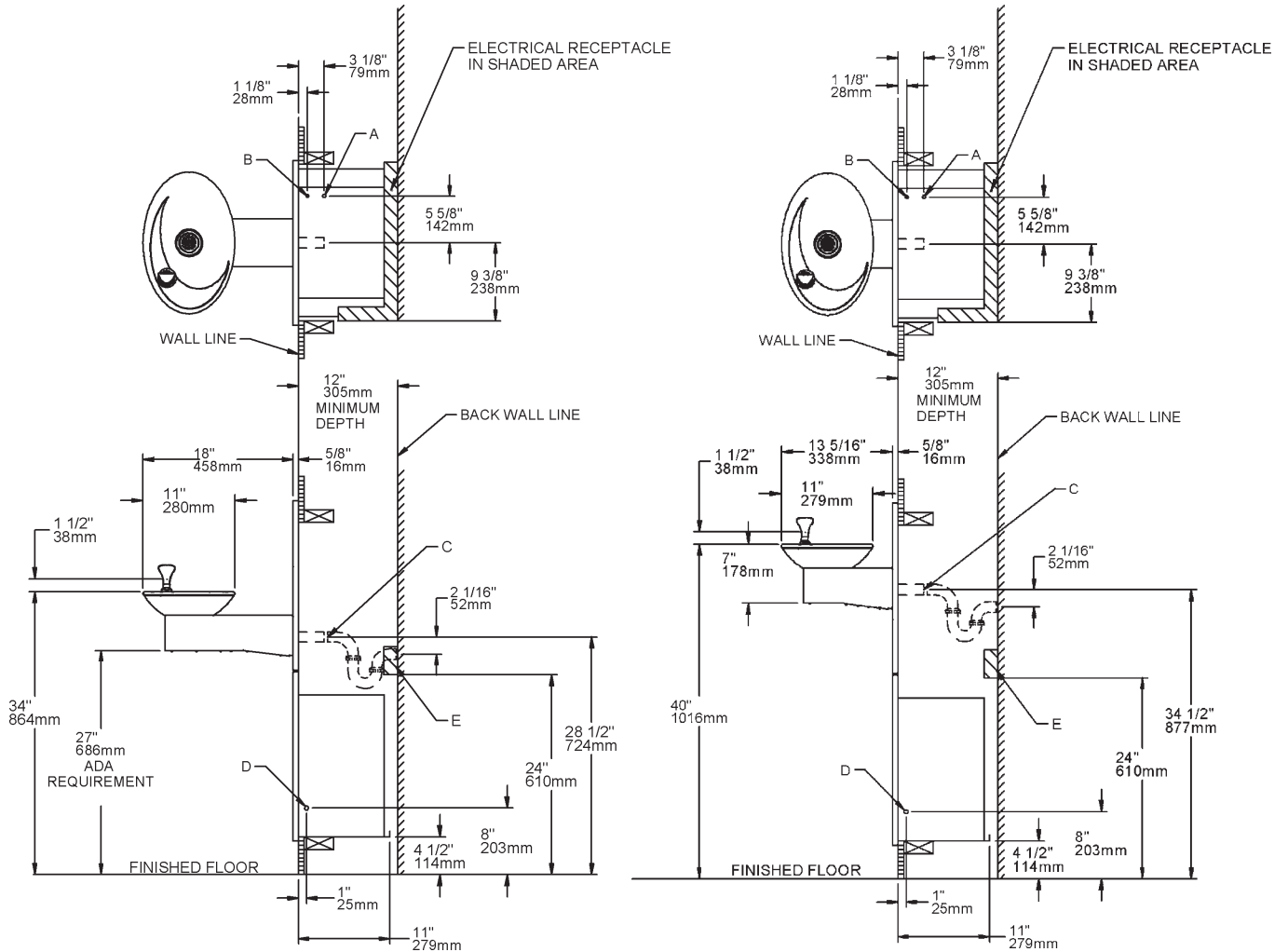

Legend

Item	Description
A	1/4" O.D. Tube - Water Outlet Connection
B	3/8" O.D. Tube - Water Inlet Connection
C	1-1/4" O.D. Waste Tube
D	Electrical Inlet on Chiller
E	Electrical Outlet Location. Additional UL/CSA listed grounded outlet (By others) required for 115 Volt, 60Hz.

Figure 11 – OVL-II EREE-Q/OVL-II SREE-Q Rough-In Dimensions

REQUIRED TOOLS AND MATERIALS

These tables show special tools and/or additional materials (not provided) which are necessary to complete installation of these units:

Special Tools

Item	Description	Quantity
	None	

Additional Materials

Item	Description	Quantity
1	Unplated copper inlet pipe	Quantity
2	Service Stop	Quantity

OVL-II EREE-Q/SREE-Q/SEREE-Q/ESREE-Q INSTALLATION

1. **Assemble and** place frame in wall as shown on preceding pages.
2. **Install chiller:** Remove front panel of chiller. **Remove and discard cardboard inner pack from between compressor and side panel.** Slide chiller onto the shelf and position it to the left on the shelf.

NOTE: Building construction must allow for adequate air flow on both sides, top and back of chiller. A minimum of 4" (102mm) on both sides and top is required. See chiller installation for additional instructions.

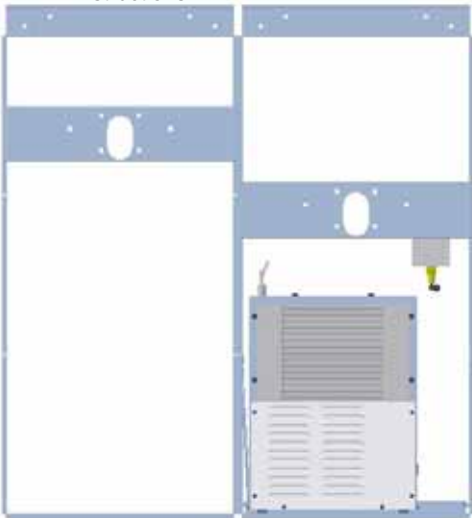

Figure 12 – Chiller Installation

3. **Attach solenoid valve assembly to the underside of cross member of mounting frame on electronic sensor unit.** (See Fig. 7).
4. **Make water supply connections.** Inlet port is marked on the chiller (1/4" O.D. copper tube). Bend the copper tube (provided) at an appropriate length from the chiller to opening in frame. Install the in-line strainer (provided with chiller) by pushing it in until it reaches a positive stop, approximately 3/4" (19mm) on the marked chiller inlet port (See Figs. 17 & 18). Attach an unplated and deburred copper water inlet line and a service stop (not provided) to the chiller. Turn on the water supply and flush the line thoroughly.
5. **Make connection between remote chiller outlet tube and solenoid valve assembly.** Outlet port is marked on the chiller (1/4" O.D. copper tube). Install a 1/4" union/tee (provided) on the marked chiller outlet port. Insert one end of 1/4" poly tubing into the union/tee and the other end into the straight fitting on the solenoid valve assy (See Figs. 17 & 18)
6. **Hang the upper panel on the mounting frame hanger.** Align holes in the panel with the holes in the mounting frame. Be sure that panel is engaged with hanger at top of frame before releasing it.

97882C - (Rev. E - 4/07)

7. **Install fountain.** Remove bottom access panel on underside of fountains and **SAVE** the screws. Mount the fountains to the upper panel and frame with (4) 5/16" x 3/4" (19mm) long bolts and nuts provided. Tighten securely.

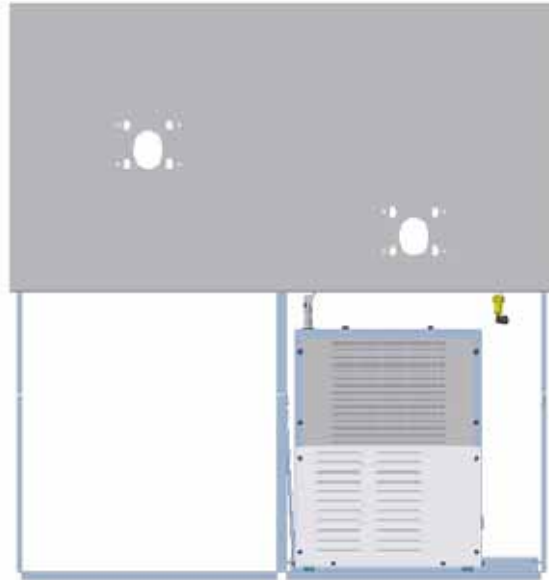

Figure 13 – Upper Panel Installation

Note: With OVL-II SEREE-Q or OVL-II ESREE-Q models, the standard reach fountain must be mounted at the upper position on panel.

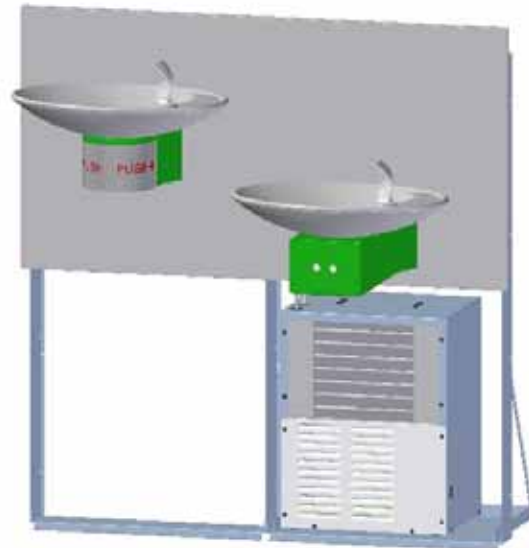

Figure 14 – Fountain Installation

8. **Connect the fountain drain waste tube to the building sanitary sewer system.** Connection should be made in compliance with local plumbing code requirements. (Note: Plumbing trap is not included with the fountain).
9. **Make connection between solenoid valve assembly and fountain(s).** Insert the 1/4" poly tubing coming from the fountain with sensor into the solenoid valve. Insert the 1/4" poly tubing coming from the fountain with push button into the tee (See Figs. 17 & 18).
10. **Connect power cord of sensor to solenoid valve by running it through the back panel and connecting it as shown in Fig. 26.** Connectors may be connected to either terminal on solenoid valve. Attach ground wire to solenoid valve bracket with green ground screw.

11. **Turn on water supply and check for leaks.** Release air from tank by interrupting infrared beam; a steady stream of water assures all air is removed. The sensor has a 30 second maximum **ON** time. It may be necessary to step away from beam a few times to allow chiller tank to fill.

CAUTION: **DO NOT SOLDER** tubes while inserted into the strainer as damage to o-rings may result.

12. **These products are designed to operate on 20-105 PSIG supply line pressure.** If inlet pressure is above 105 PSIG, a pressure regulator must be installed in the supply line.

CAUTION: Any damage caused by connecting these products to a supply line with pressure lower than 20 PSIG or higher than 105 PSIG **IS NOT** covered under warranty.

13. **Make electrical connections to the chiller.** See chiller instructions.
14. **Check stream height from bubbler.** Stream height is factory set at 35-40 PSI. If supply pressure varies greatly from this, please do the following. For **Pushbar units only**, remove items 2, 19, and 20 (push arm and the bottom and the top actuator plates – Figure 20) by removing the screws holding assembly together and adjust the screw on the regulator (Item 14 – Figs. 21 & 22). Clockwise adjustment will raise stream height and counterclockwise movement will lower stream height. For **Electronic sensor units only**, remove bottom access panel and turn adjustment screw on the regulator (Item 14 - Figs. 25 & 27). Clockwise adjustment will raise stream height and counterclockwise movement will lower stream height. For best adjustment, stream height should be approximately 1-1/2" (38mm) above the bubbler guard. (See Figure 16).
15. **Mount lower panel.** Loosen the two (2) #10-24 x 5/8" (16mm) screws at frame bottom lip. Slide upper tongue of lower panel under lower edge of already installed upper panel. Tighten previously loosened screws securely.
16. **Replace bottom access panel** to fountain basin using screws provided. Tighten securely.

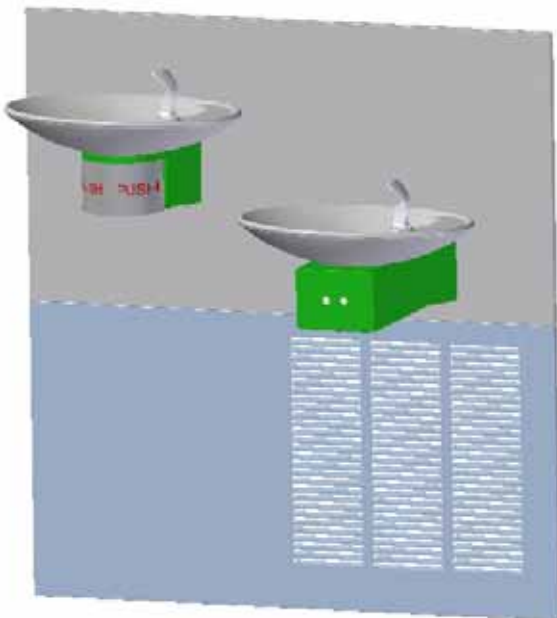

Figure 15 – Lower Panel Installation

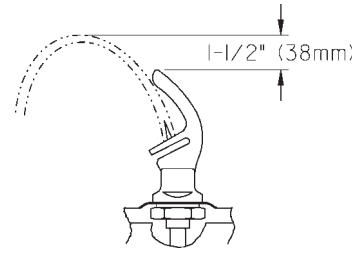

Figure 16 – Stream Height

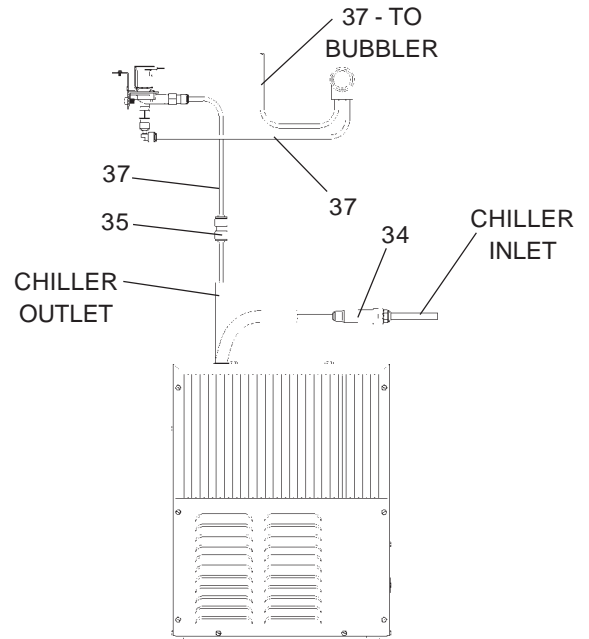

Figure 17 – OVL-II EREE-Q/SREE-Q Tube Routing

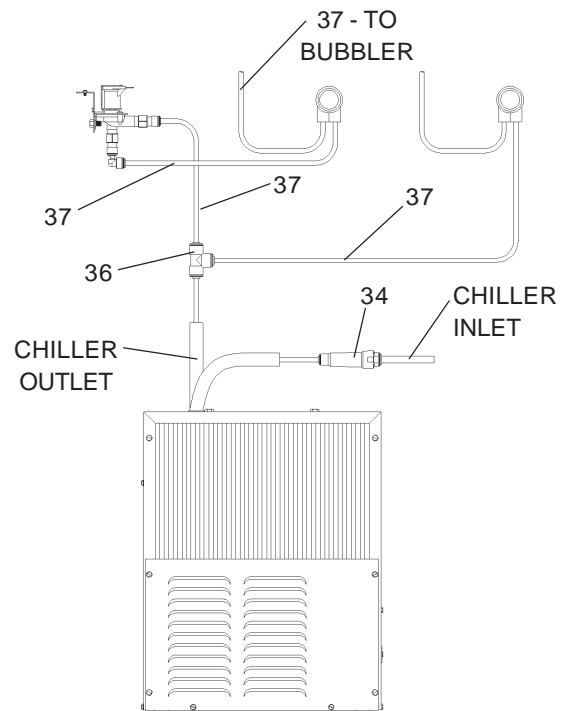

Figure 18 – OVL-II SEREE-Q/ESREE-Q Tube Routing

TROUBLESHOOTING & MAINTENANCE

Orifice Assembly: Mineral deposits on orifice can cause water flow to spurt or not regulate. Mineral deposits may be removed from the orifice by poking with a small round file not over 1/8" diameter, or using a small diameter wire.

CAUTION: DO NOT file or cut orifice material.

Stream Regulator: If orifice is clean, regulate flow as in Step 14 of the installation instructions. If replacement is necessary, see parts list for correct regulator part number.

CAUTION: To preserve the quality and keep this AZTEC GOLD finish clean and spot free, clean this surface with only mild detergent or window cleaner and polish with a soft cloth. DO NOT use any abrasive cleaners or harsh chemicals. They WILL damage the finish!

Sensor Control: The sensor has a 2 second delay time. If sensor fails to operate valve mechanism or operates erratically, check the following:

- a) Ensure there are no obstructions within a 40 inch radius from the front of fountain.
- b) Check wire connections at the solenoid valve and at the sensor. **CAUTION:** Make sure unit is unplugged before checking any wiring.
- c) Ensure proper operation of solenoid valve. If there is an audible clicking sound yet no water flows, look for a obstruction in the valve itself or elsewhere in the water supply line. **WARNING:** Do not expose sensor to direct sunlight.

Sensor Range Adjustment: The electronic sensor used in this fountain is factory pre-set for a "visual" range of 36 inches. If actual range varies greatly from this, or a different setting is desired, follow the range adjustment procedure below:

- a) Remove bottom cover of fountain.
- b) Remove sensor by removing washers and nuts that secure sensor on studs.
- c) Locate range adjustment screw between the red lenses of the sensor, then with a small tip screwdriver, rotate the range adjusting screw clockwise to increase range or counter-clockwise to decrease range. 1/4 turn of screw is equal to approximately 12 - 18 inches of range. **CAUTION:** Complete range of sensor (24 - 46 inches) is only one turn of the adjusting screw.
- d) Remount sensor on studs and replace bottom cover.

Actuation of Quick Connect Water Fittings: Cooler is provided with lead-free connectors which utilize an o-ring water seal. To remove tubing from the fitting, relieve water pressure, push in on the gray collar while pulling on the tubing (See Figure 19). To insert tubing, push tube straight into fitting until it reaches a positive stop (approximately 3/4").

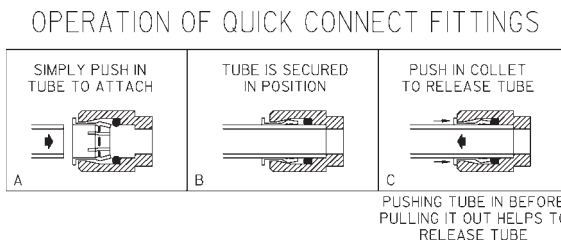

Figure 19 – Quick Connect Fittings

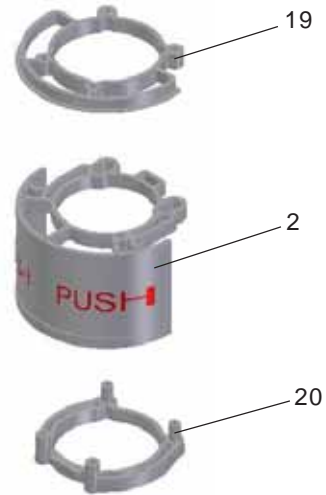

Figure 20 – Push Arm Mechanism

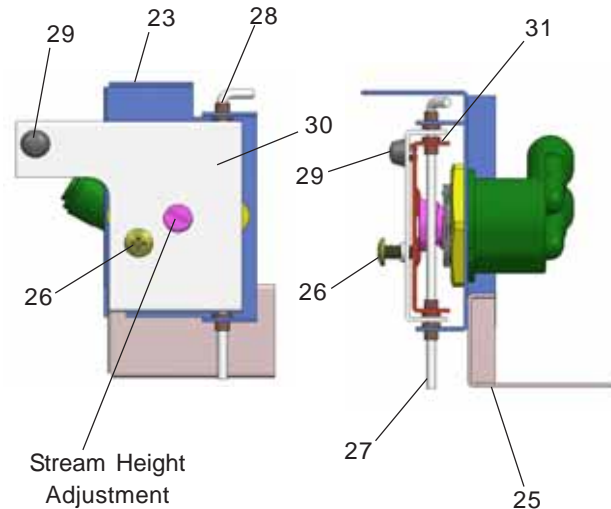

Figure 21 – Regulator Mounting Mechanism

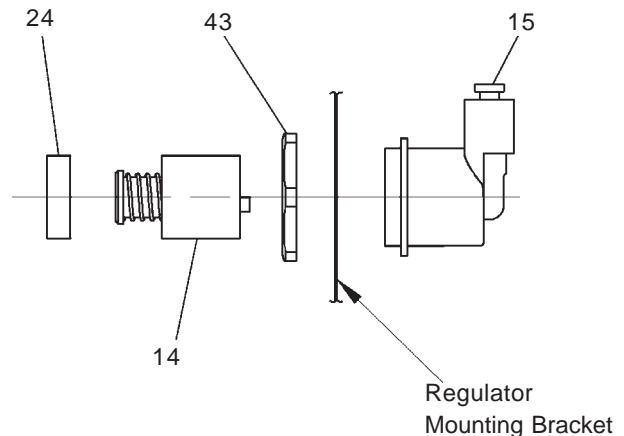

Figure 22 – Regulator Assembly

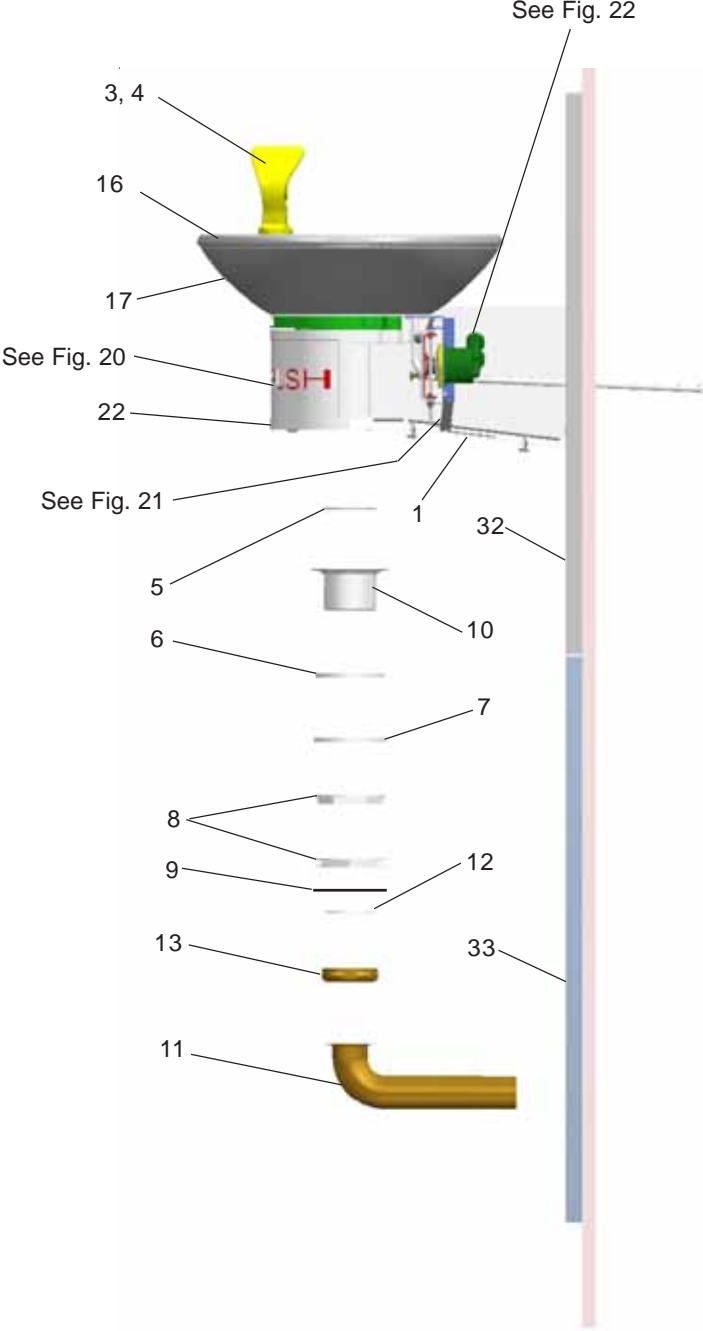

Figure 24 – Push Bar Fountain Assembly - Side View

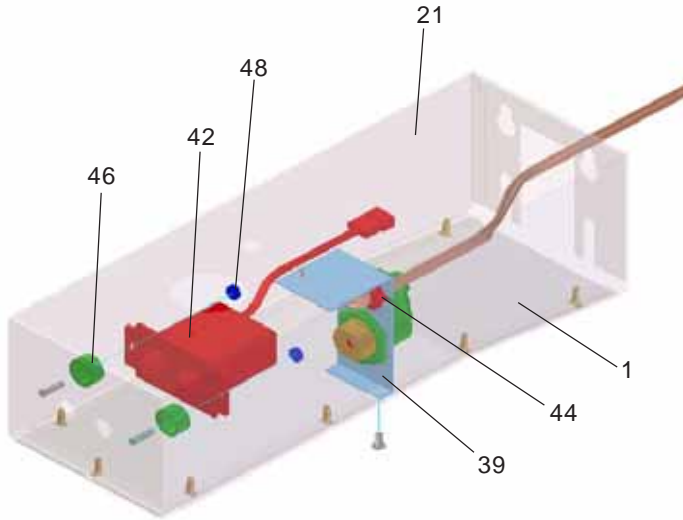

Figure 25 – View of Electronic Sensor

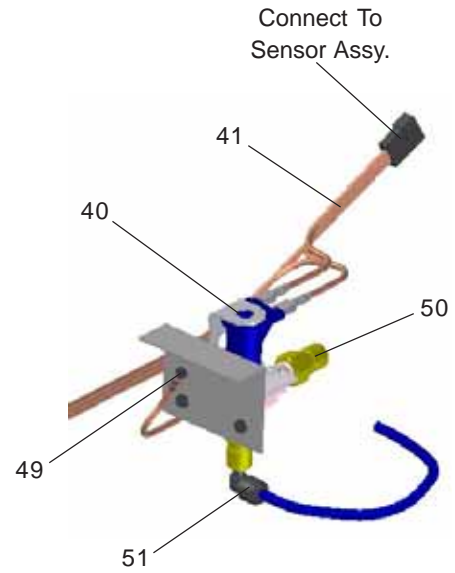

Figure 26 – View of Solenoid Valve

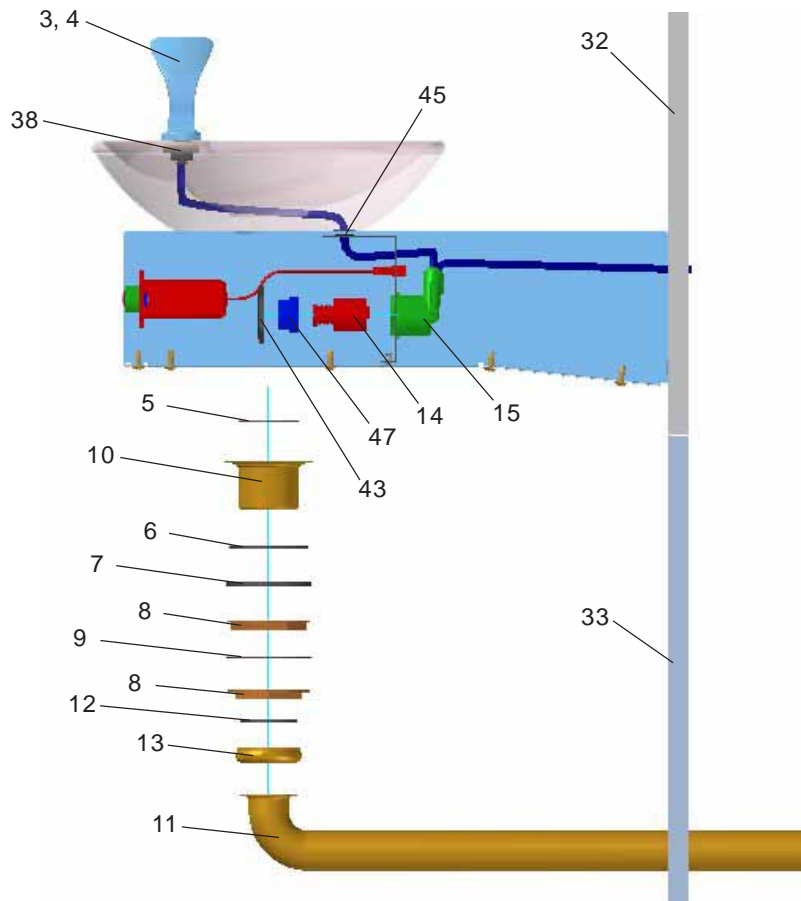

Figure 27 – Electronic Sensor Fountain Assembly - Side View