

Halsey Taylor Owners Manual

Non-Refrigerated Fountains

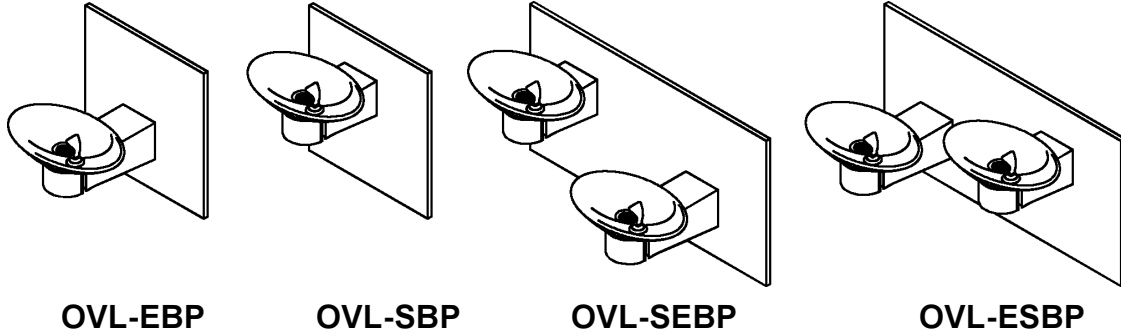

Installer

To assure you install this model easily and correctly, PLEASE READ THESE SIMPLE INSTRUCTIONS BEFORE STARTING THE INSTALLATION. CHECK YOUR INSTALLATION FOR COMPLIANCE WITH PLUMBING, ELECTRICAL AND OTHER APPLICABLE CODES. After installation, leave these instructions inside the fountain for future reference.

IMPORTANT

ALL SERVICE TO BE PERFORMED BY AN AUTHORIZED SERVICE PERSON

IMPORTANT! INSTALLER PLEASE NOTE.

THE GROUNDING OF ELECTRICAL EQUIPMENT SUCH AS TELEPHONE, COMPUTERS, ETC. TO WATER LINES IS A COMMON PROCEDURE. THIS GROUNDING MAY BE IN THE BUILDING OR MAY OCCUR AWAY FROM THE BUILDING. THIS GROUNDING CAN CAUSE ELECTRICAL FEEDBACK INTO A FOUNTAIN, CREATING AN ELECTROLYSIS WHICH CAUSES A METALLIC TASTE OR AN INCREASE IN THE METAL CONTENT OF THE WATER. THIS CONDITION IS AVOIDABLE BY USING THE PROPER MATERIALS AS INDICATED. ANY DRAIN FITTINGS PROVIDED BY THE INSTALLER SHOULD BE MADE OF PLASTIC TO ELECTRICALLY ISOLATE THE FOUNTAIN FROM THE BUILDING PLUMBING SYSTEM.

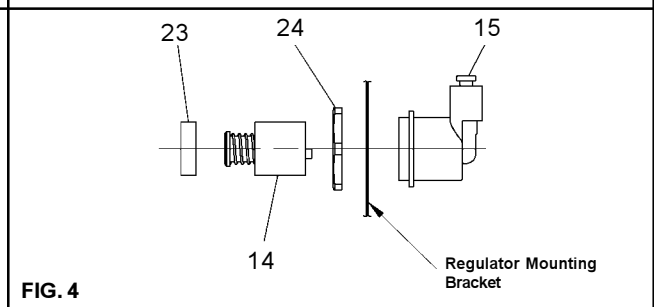
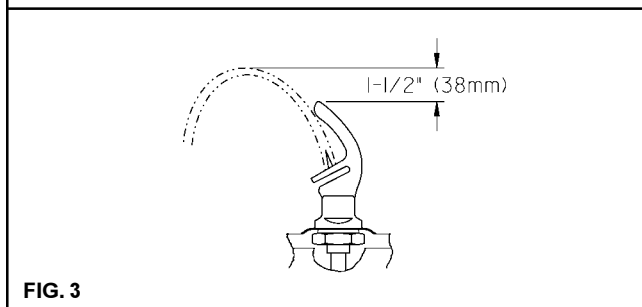
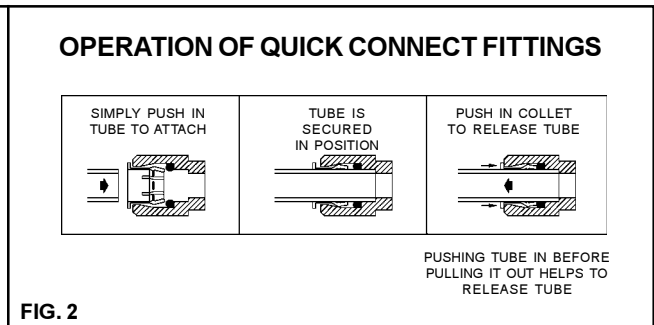
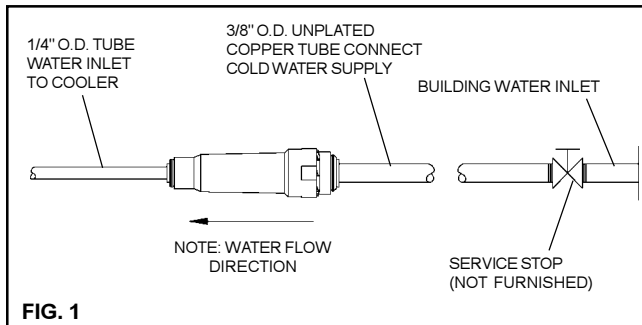

OVL - EBP/SBP/SEBP/ESBP COOLER INSTALLATION

1. **Wall should already be framed for the fountain** using the rough-in dimensions shown in Fig's. 5,6,7, or 8. Shown dimensions pertain to installation location (framing must support up to 150 lbs. weight for single fountain and 300 lbs. for dual fountains). These dimensions are required for compliance with ANSI Standard A117.0.
2. **Attach hanger bracket to wall** as shown in Fig's. 5,6,7, or 8 using 5/16" x 3/4" long bolts and flat washers (not provided). Tighten securely.
3. **Install back panel.** Place the upper edge of the panel above hanger on the wall. Slide the panel down until it engages the hanger. Be sure back panel is firmly engaged before releasing it.
4. **Install rough-in plumbing** as shown in Fig's. 5,6,7, or 8. Waste line should extend a minimum of 2" (51mm) thru the back panel. Run supply water inlet line thru back panel. Install a service stop (not provided). Turn on supply water and flush thoroughly.
5. **Remove bottom access panel** from fountain basin and save the screws. Install the fountain to the back panel and wall using (4) 5/16 " x 2" long lag bolts and washers (not provided) thru holes in back panel. Tighten securely.
6. **Cut waste tube to required length** using plumbing hardware and trap (not provided) as a guide. Install hardware and trap. Tighten securely.
7. **Make water supply connections** from service stop to the fountain strainer. Insert the water inlet line into the inlet side of strainer until it reaches a positive stop - about 3/4" (See Fig. 2). Turn on water supply and check for leaks. Newly installed water supply line should be insulated after leak check is completed. **DO NOT SOLDER TUBES INSERTED INTO THE STRAINER AS DAMAGE TO THE O-RINGS MAY RESULT.**
8. **Check stream height from bubbler.** Stream height is factory set at 45-50 PSI. If supply pressure varies greatly from this, adjust the screw on regulator (item 14, on page 1). Clockwise adjustment will raise stream height and counter-clockwise will lower stream height. For best adjustment stream height should be approximately 1-1/2" (38mm) above the bubbler guard. (See Figure 3)
9. **Water Valve Mechanism - ADJUSTMENT PROCEDURE:**
 - Turn adjustment screw (Item 26, page 7) counter-clockwise until water flow from bubbler starts
 - Turn adjustment screw clockwise until water flow stops, then turn an additional 1/2 turn
10. **Replace bottom access panel** to fountain using the screws provided. Tighten securely.

ROUGH-IN FOR OVL-EBP

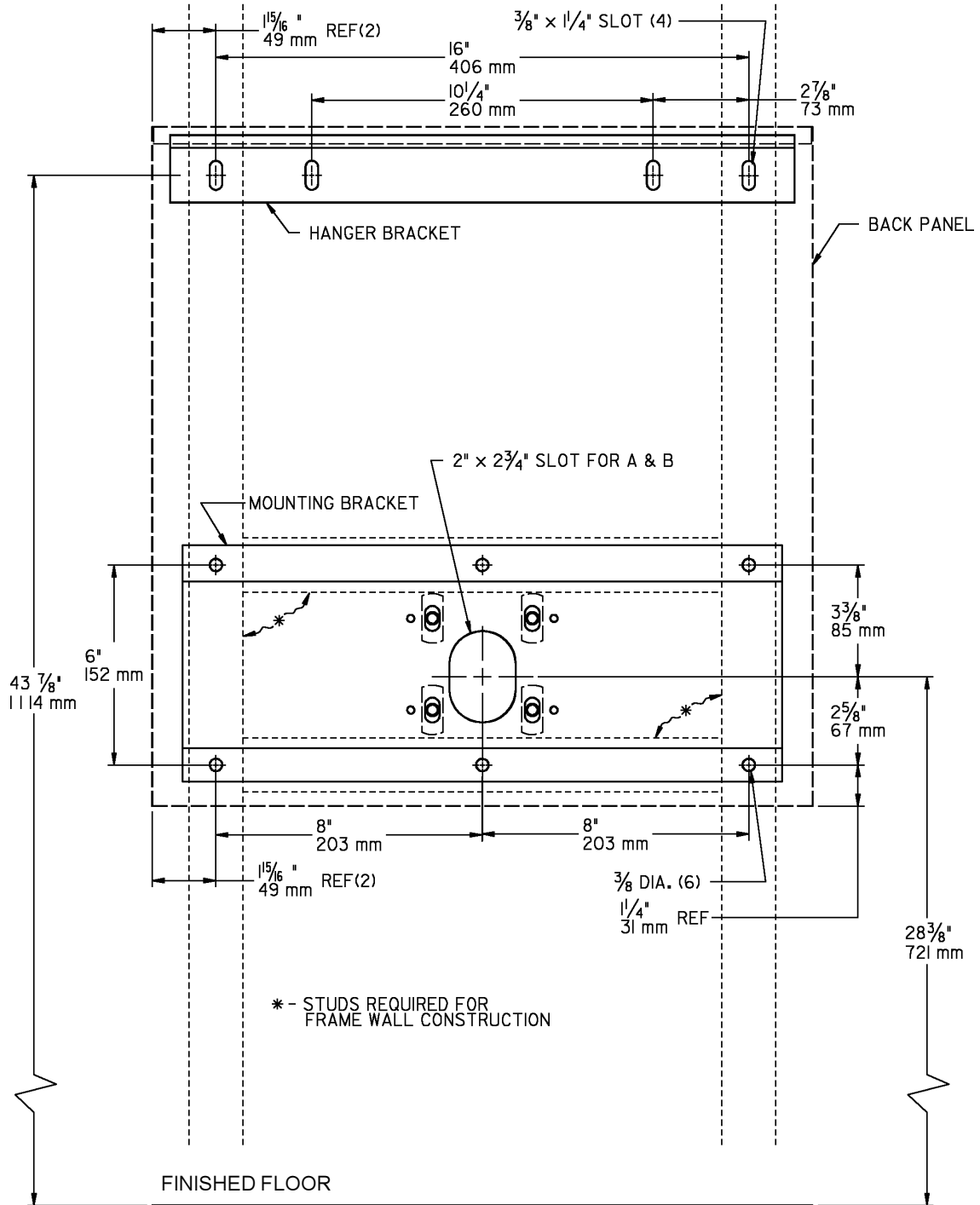

LEGEND:

A = 1-1/4" O.D. Waste Tube (Trap And Elbow Not Provided)

B = 3/8" O.D. Unplated Copper Tube Connect (Water Inlet)

FIG. 5

ROUGH-IN FOR OVL-SBP

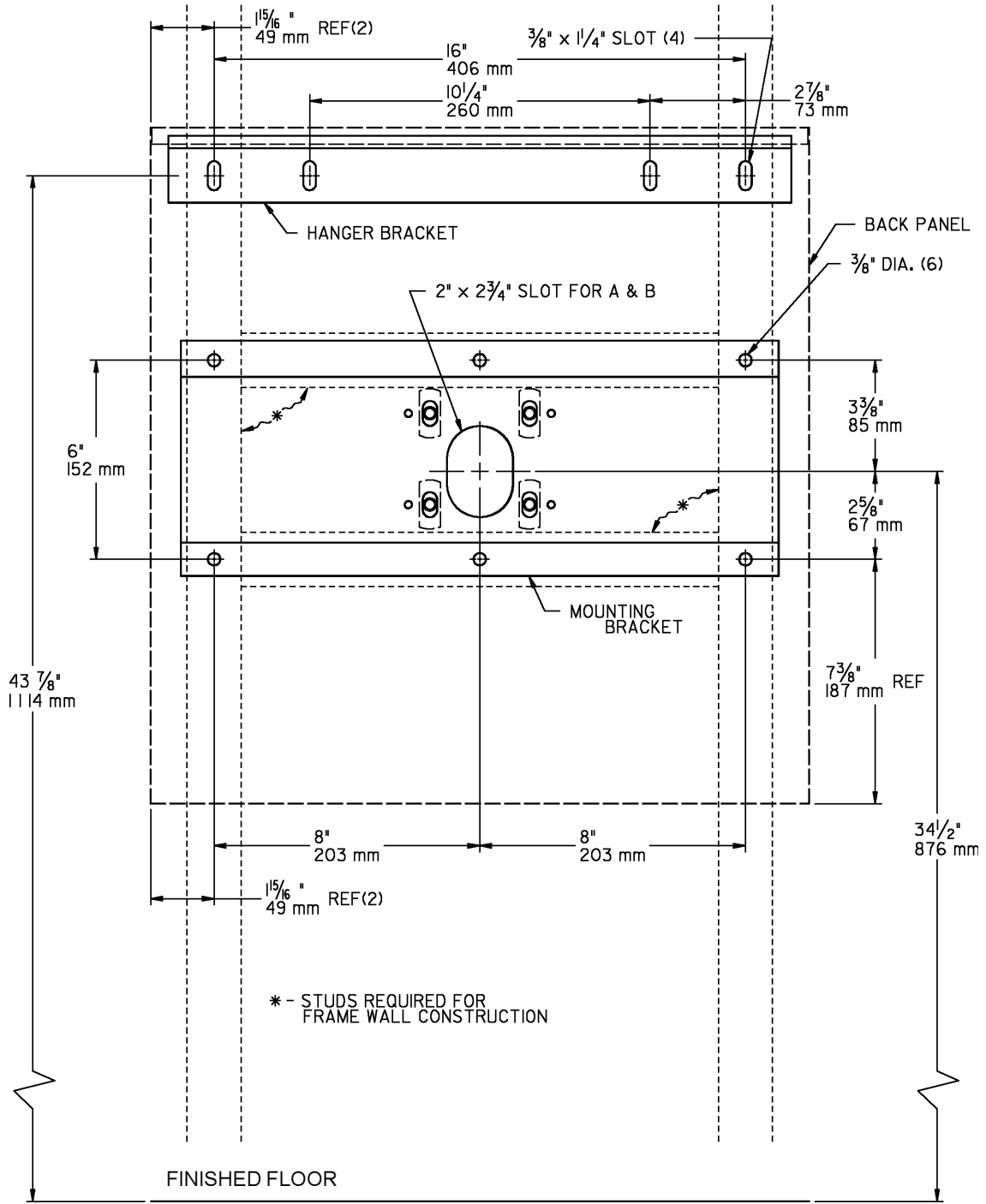

LEGEND:
A = 1-1/4" O.D. Waste Tube (Trap And Elbow Not Provided)
B = 3/8" O.D. Unplated Copper Tube Connect (Water Inlet)

FIG. 6

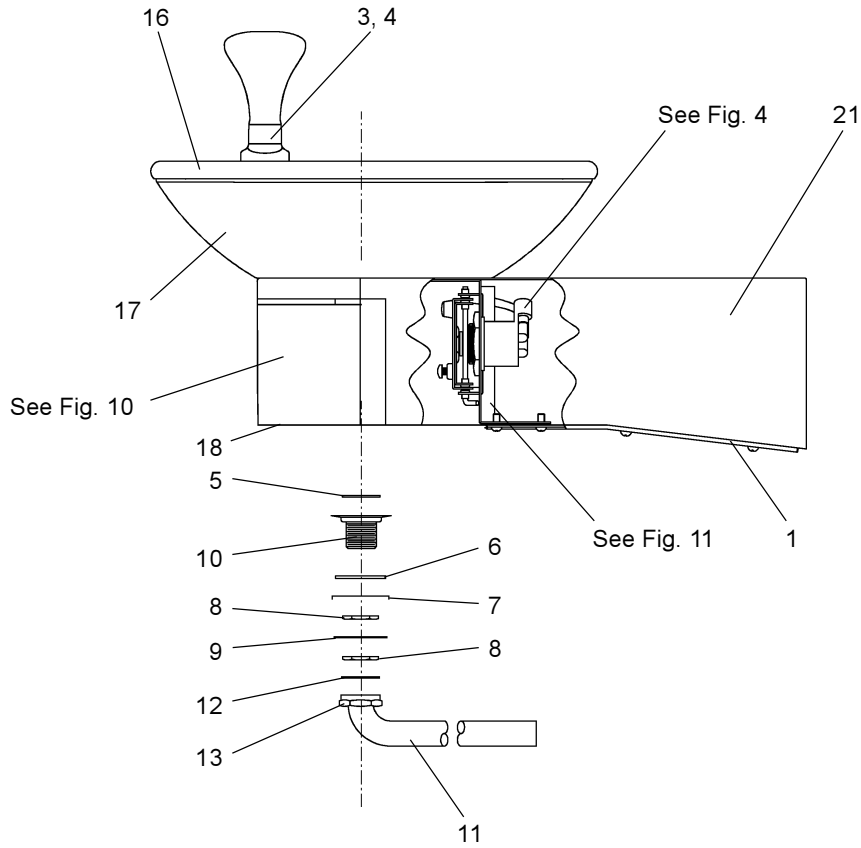

FIG. 9

PUSH BAR MECHANISM

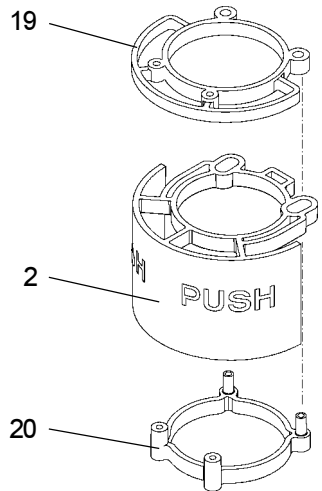

FIG. 10

REGULATOR MOUNTING MECHANISM

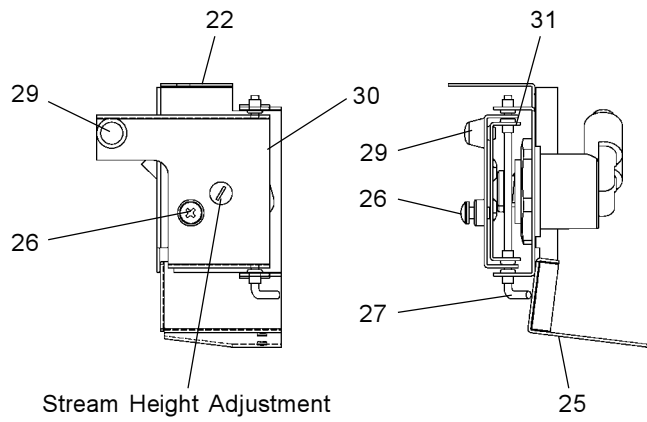

FIG. 11

PARTS LIST		
ITEM NO.	PART NO.	DESCRIPTION
1	26990C	Bottom Cover (OVL-S)
	26988C	Bottom Cover (OVL-E)
2	55836C	Push Arm Actuator
	55991C	Push Arm Actuator - AG
3	51546C	Bubbler
	45396C	Bubbler - AG
4	100322740560	Bubbler Gasket
5	160270508640	Strainer Plate
	45400C	Strainer Plate - AG
6	101570540560	Drain Gasket
7	51575C	Packing Ring
8	110346208550	Drain Nut
9	101637451550	Friction Ring
10	161637308640	Drain Plug
	45398C	Drain Plug - AG
11	45683C	Waste Elbow (OVL-E)
	45682C	Waste Elbow (OVL-S)
12	100023340560	Waste Tube Gasket
13	161570808550	Slip Nut
14	61314C	Regulator
15	50986C	Regulator Holder
16	27006C	Basin
	27342C	Basin - AG
17	27000C	Basin Liner
	27344C	Basin Liner - AG
18	70861C	Screw #10-24 x 2
19	55840C	Top Plate - Actuator
20	55839C	Bottom Plate - Actuator
21	27002C	Arm w/Weldnuts (OVL-E)
	27338C	Carrier Arm - AG (OVL-E)
	27004C	Arm w/Weldnuts (OVL-S)
	27340C	Carrier Arm - AG (OVL-S)
22	26992C	Regulator Mounting Bracket
23	15005C	Nut - Retaining
24	40045C	Nut Hex - UNPLTD
25	27008C	Reaction Bracket
26	70856C	Screw #10-24 x .38 PHMS
27	70854C	Rod - Pivot
28	50198C	Bushing Snap
29	51468C	Bumper - Reg. Valve Assy
30	22646C	Reg. Arm Assy
31	22635C	Arm - Reg. Adjust
32	22797C	Back Panel (OVL-EBP)
	27885C	Back Panel (OVL-EBP) (AG)
	22799C	Back Panel (OVL-SBP)
	27887C	Back Panel (OVL-SBP) (AG)
	26958C	Back Panel (OVL-SEBP)
	27889C	Back Panel (OVL-SEBP) (AG)
	22795C	Back Panel (OVL-ESBP)
	27891C	Back Panel (OVL-ESBP) (AG)
33	27084C	Fountain Mounting Bracket
NS	27089C	Back Panel Hanger Bracket (OVL-EBP/SBP)
NS	27090C	Back Panel Hanger Bracket (OVL-SEBP/ESBP)
NS	55996C	Strainer
NS	15008C	Bubbler Nipple Assy
NS	55994C	Tubing - Poly (Order in Feet)

TROUBLE SHOOTING AND MAINTENANCE

Orifice Assy: Mineral deposits on orifice can cause water flow to spurt or not regulate. Mineral deposits may be removed from the orifice with a small round file or small diameter wire.

CAUTION: DO NOT file or cut orifice material.

Stream Regulator: If orifice is clean, regulate flow as in "STREAM HEIGHT ADJUSTMENT" instructions on pg 2. If replacement is necessary, see parts list for correct regulator part number.

Actuation of Quick Connect Water Fittings: Fountain is provided with lead-free connectors which utilize an o-ring water seal. To remove tubing from the fitting, relieve water pressure, push in on the gray collar while pulling on the tubing.(see Fig.2) To insert tubing, push tube straight into fitting until it reaches a positive stop, approximately 3/4".

CAUTION: Cleaning of Aztec Gold Models requires special care.

Outer surfaces must be cleaned with a mild detergent or mixture of vinegar and water only, rinsed and wiped dry. Abrasive and acidic cleaners may eventually damage the Aztec Gold finish.

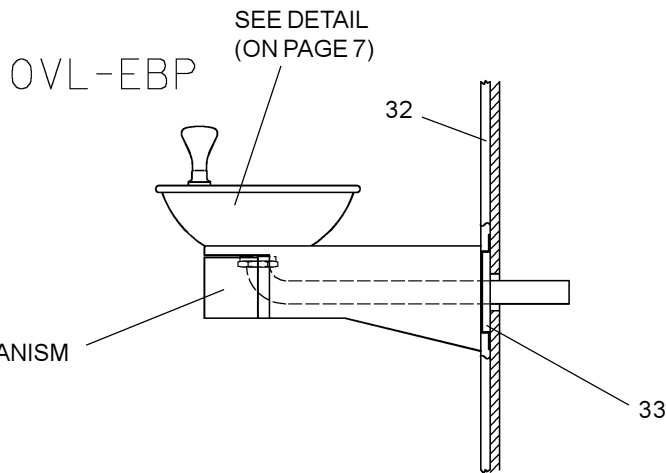
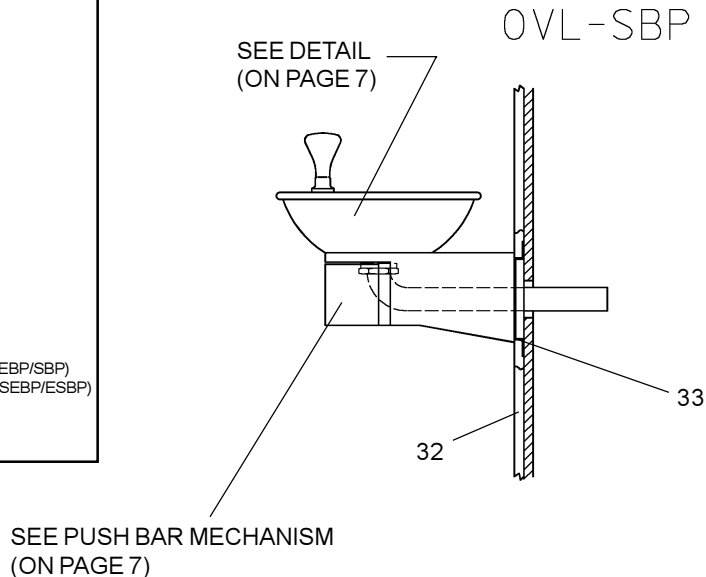

Halsey Taylor
 2222 CAMDEN COURT
 OAK BROOK, IL 60523
 630.574.3500

PRINTED IN U.S.A.

FOR PARTS, CONTACT YOUR LOCAL DISTRIBUTOR OR CALL 1.800.323.0620