



Water Coolers

BARRIER-FREE FROST-RESISTANT MODULAR

M140RFZ

Suggested Specification

Model M140RFZ is a non-refrigerated, frost-resistant drinking fountain. Fountain is activated by a push button and shall be designed to eliminate splashing and standing water. Bubbler shall have flexible bubbler guard and operate between 20 and 120 PSI. A plumbing box containing an air operated valve and drain system shall be included for remote mounting in a heated area. A wall panel and mounting bracket shall be included with the fountain. Shall be listed by Underwriters' Laboratories to U.S. and Canadian standards. This unit shall comply with the Safe Drinking Water Act and Lead Contamination Control Act. When properly installed unit shall be in compliance with ADA.

Model

M140RFZ is a distinctive, space saving, frost resistant fountain that serves the disabled as well as the able-bodied. It can be installed with the M110RFZ to provide split level combination.

Standard Features

- > Waterways are Lead-Free in Materials & Construction
- > Stainless Steel Surfaces
- > Stainless Steel Wall Panel
- > Heavy duty galvanized steel wall mounting bracket
- > Air-Operated Valve mounted in plumbing box to be located in heated area inside wall.
- > Air valve and drain components mounted on heavy gauge plate, furnished with full cover
- > Limited 1-Year Warranty

Finishes

- > Standard Finish: Stainless Steel

Installation

- > Prior to roughing-in, consult local, state and federal codes for proper mounting heights and wall mounting plate.
- > Shipped with complete instructions and wall mounting bracket.
- > Prior to roughing-in, review factory mounting and installation procedures.
- > Mounting template available.



ADA compliant for both adult or child when properly installed



Components in this cooler are lead free as defined by the Safe Drinking Water Act Amendments of 1986, and the Lead Contamination Control Act of 1988.

Limited 1-Year Warranty (Continental limits of the United States and Canada): One year from date of installation on parts only. Detailed warranty certificate enclosed with each drinking fountain; sample copy available upon request.

Export Warranty: One year on component parts. Detailed warranty certificate enclosed with each drinking fountain; sample copy available upon request.

Models covered by this specification comply with all known Plumbing Codes. Listed by Underwriters' Laboratories to U.S. and Canadian standards and European Union Directives.



Physical Dimensions In Inches						
Model	Style	Height	Width	Depth	Extended From Wall	Net Weight Approx.
M140RFZ	Radii Modular Frost-Resistant	6 1/8"	13 7/8"	18 1/2"	16 1/2"	46 lbs

Specifications subject to change without notice

OASIS® RADII™ FROST RESISTANT MODULAR DRINKING FOUNTAIN M140RFZ

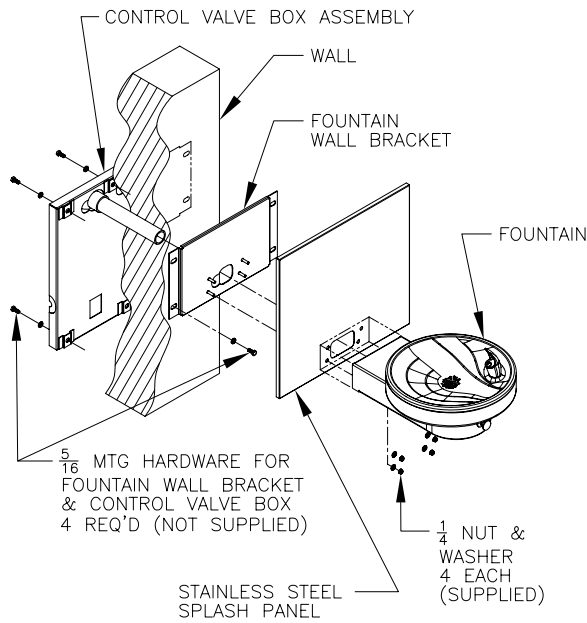

FOUNTAIN & CONTROL VALVE BOX ASSEMBLY

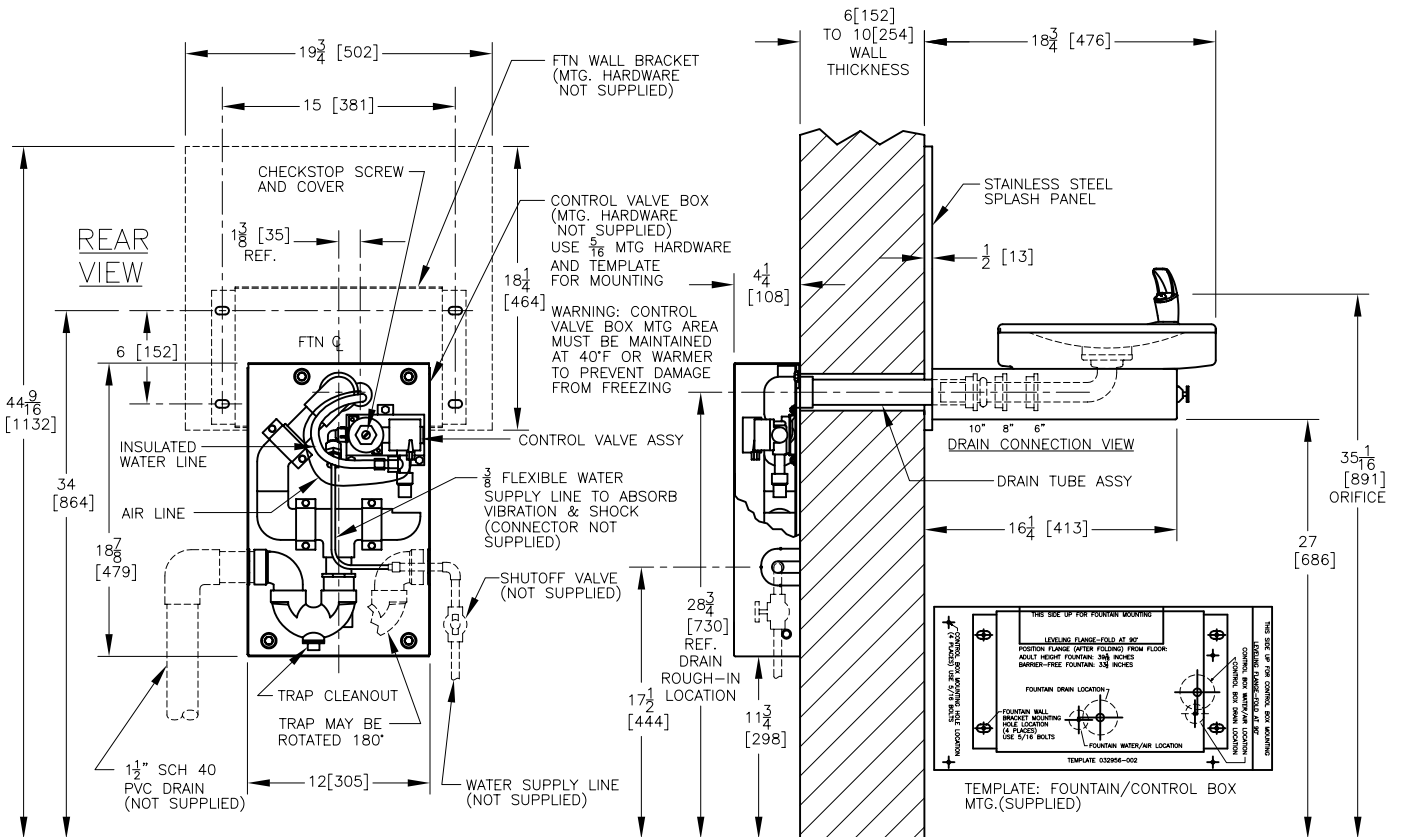
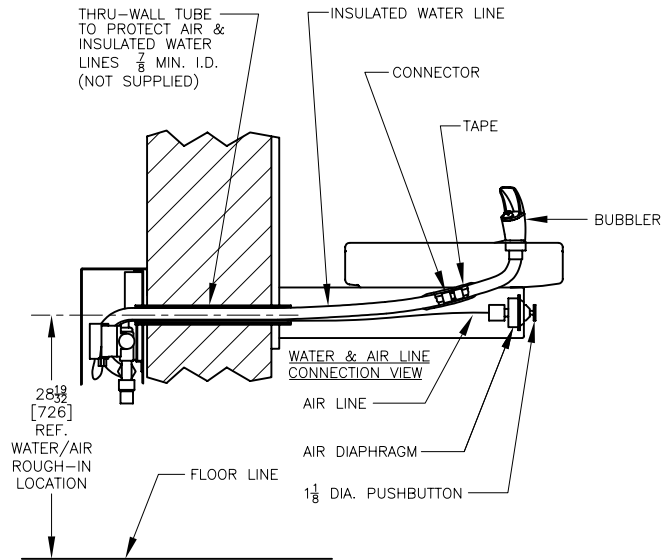

ALL DIMENSIONS ARE IN INCHES.
DIMENSIONS IN BRACKETS [] ARE IN MILLIMETERS.

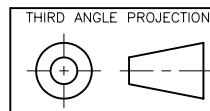

ROUGHING-IN
AND
DIMENSIONAL DRAWING