

Halsey Taylor OWNERS MANUAL

HVRFR™ Series Barrier-Free Water Coolers

Uses HFC-134A refrigerant

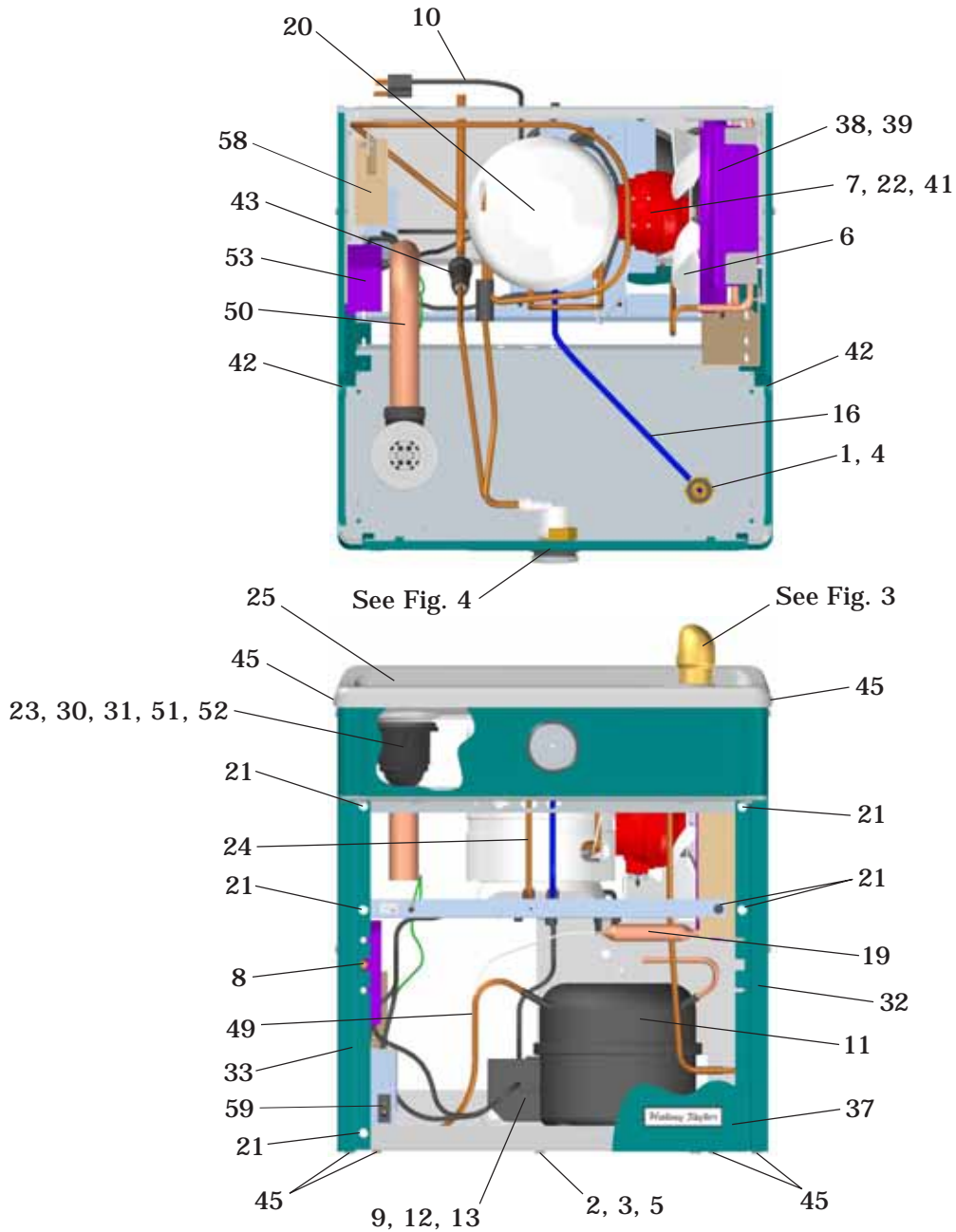

Fig. 1

NOTE: Non-refrigerated units do not include all electrical and refrigeration components shown above. Other components and rough-in are the same as shown.

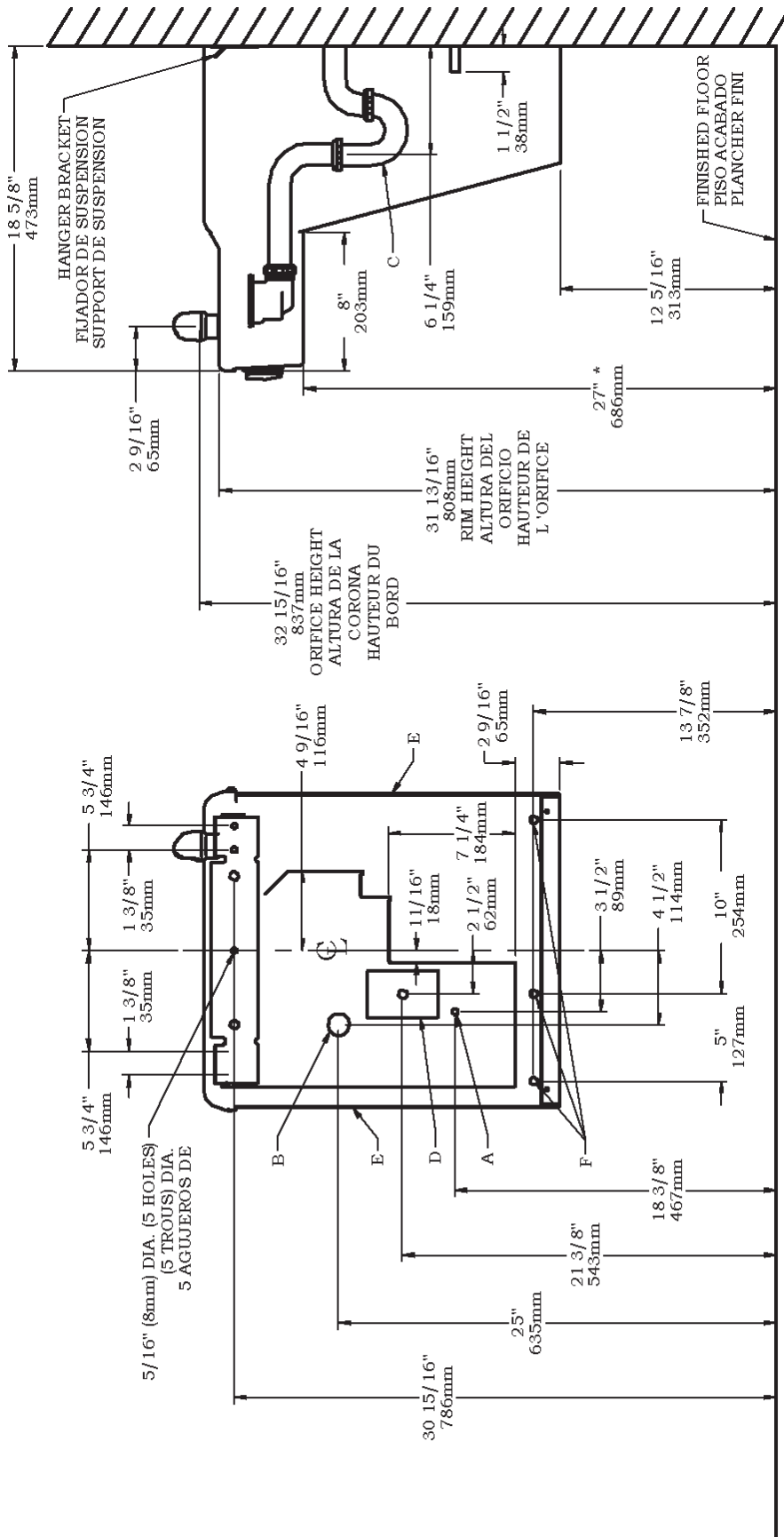

Fig. 2

REDUCE HEIGHT BY 3" FOR INSTALLATION OF CHILDRENS ADA COOLER

LEGEND/LEYENDA/LÉGENDE

A = RECOMMENDED WATER SUPPLY LOCATION. SHUT OFF VALVE (NOT FURNISHED) TO ACCEPT 3/8" O.D. UNPLATED COPPER TUBE.

B = RECOMMENDED LOCATION FOR WASTE OUTLET 1-1/4" O.D. DRAIN

C = 1-1/4 TRAP NOT FURNISHED**

D = ELECTRICAL SUPPLY (3) WIRE RECESSED BOX

E = INSURE PROPER VENTILATION BY MAINTAINING 6" (152 mm) (MIN.) CLEARANCE FROM CABINET LOUVERS TO WALL.

F = 7/16 BOLT HOLES FOR FASTENING UNIT TO WALL

* ADA REQUIREMENT

**IMPORTANT
ALL SERVICE TO BE PERFORMED BY
AN AUTHORIZED SERVICE PERSON**

**HANGER BRACKETS & TRAP
INSTALLATION**

- 1) Remove hanger bracket fastened to back of cooler by removing one (1) screw.
 - 2) Mount the hanger bracket and trap as shown in Figure 2.
- NOTE:** Hanger Bracket **MUST** be supported securely. Add fixture support carrier if wall will not provide adequate support.

IMPORTANT:

- 6 1/4 in. (159mm) dimension from wall to centerline of trap must be maintained for proper fit.
 - Anchor hanger securely to wall using all five (5) 1/4 in. dia. mounting holes.
- 3) Install straight valve for 3/8" O.D. tube.

INSTALLATION OF COOLER

- 4) Hang the cooler on the hanger bracket. Be certain the hanger bracket is engaged properly in the slots on the cooler back as shown in Figure 2.
- 5) Loosen the two (2) screws holding the lower front panel at the bottom of cooler base and two (2) screws at the top (**Use torx bits sold separately**). Remove the front panel and set aside.
- 6) Connect water inlet line--See Note 4 of General Instructions.
- 7) Remove the slip nut and gasket from the trap and install them on the cooler waste line making sure that the end of the waste line fits into the trap. Assemble the slip nut and gasket to the trap and tighten securely. Recommend fastening cooler to wall using 7/16 bolt holes. (see fig.2, "F")

START UP

Also See General Instructions

- 8) Stream height is factory set at 45-50 PSI. If supply pressure varies greatly from this, adjust screw using the access hole in the pushbutton (insert screwdriver). CW adjustment will raise stream and CCW adjustment will lower stream. For best adjustment, stream should hit basin approximately 6-1/2" (165mm) from bubbler.

COLOR TABLE PANEL COLOR	Item No. 32 Part No.	Item No. 33 Part No.	Item No. 34 Part No.	Item No. 35 Part No.	Item No. 36 Part No.	Item No. 37 Part No.
Stainless Steel	28525C	28528C	28519C	28522C	28516C	22955C

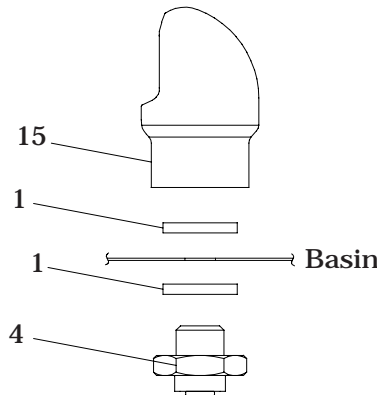

Fig. 3

VANDAL RESISTANT BUBBLER DETAIL

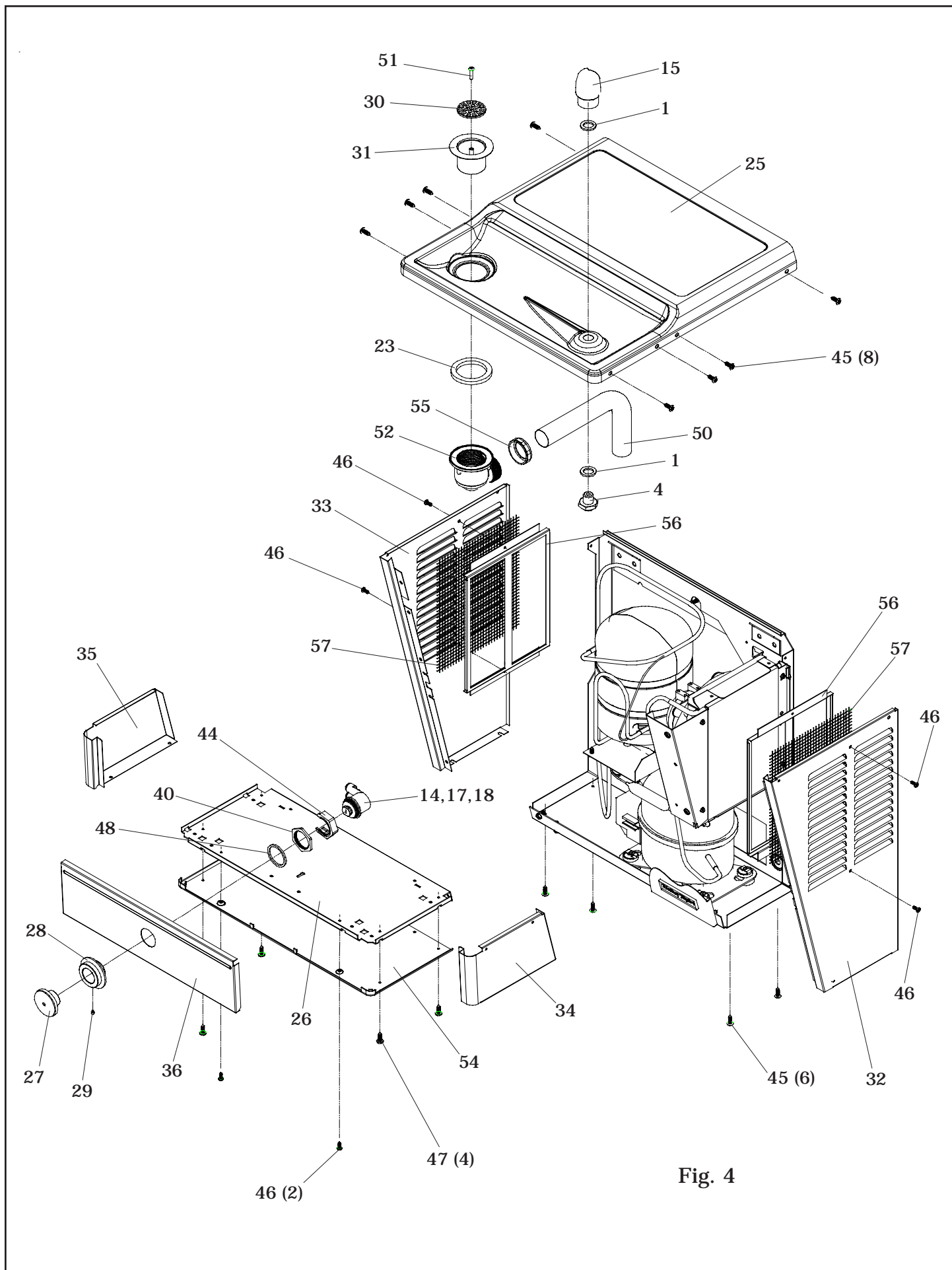

Fig. 4

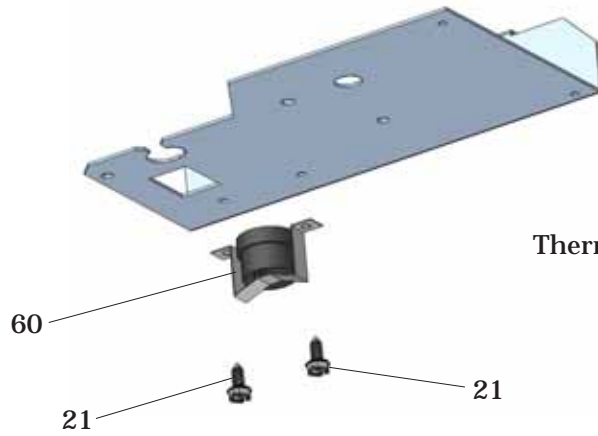
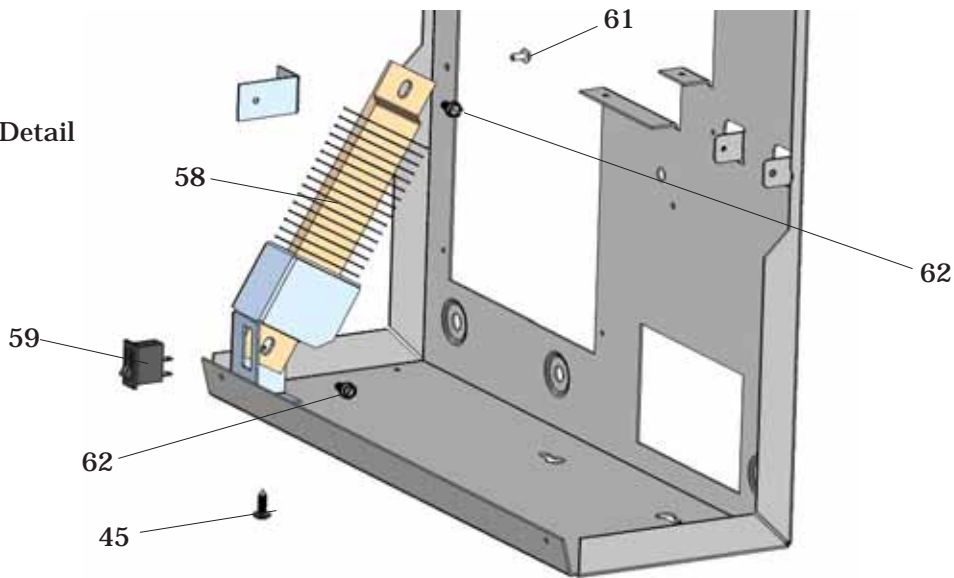

Fig. 5
Thermostat Installation Detail

Fig. 6
Heater Strip Detail



WARNING!

This unit is frost resistant down to 0° F with no wind. Prevailing winds can reduce the ability of the heater element to prevent light freezing. If the ambient air temperature will drop below 0° F, the cooler needs to be drained of all water by blowing out all water lines, evaporator (item 20), and the drain trap. A heater strip is used to heat the unit and will begin to cycle at 40° +/- 5° F. A check at this temperature will ensure the heater is working and the unit is resistant to light freezing.

ALSO, MAKE SURE THERE ARE NO PLASTIC OR FLAMMABLE COMPONENTS DIRECTLY ABOVE THE HEATER STRIP.

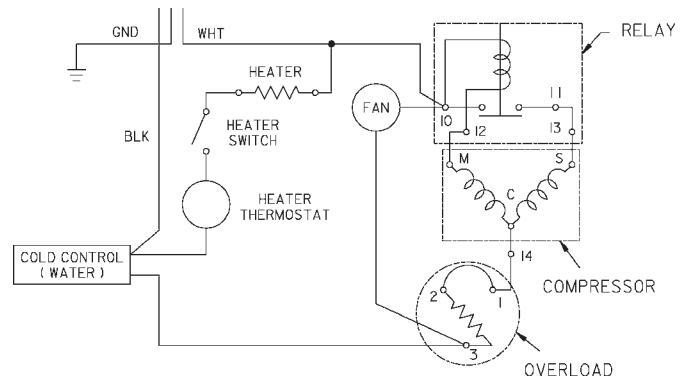

Wiring Diagram

115V PARTS LIST

ITEM NO.	PART NO.	DESCRIPTION
1	56305C	Gasket - Bubbler
2	100806740570	Grommet - Compressor Mtg.
3	101516143550	Stud - Compressor Mtg.
4	15009C	Nipple - Bubbler
5	19037000	Clip - Compressor Mtg.
6	30664C	Fan Blade
7	31490C	Fan Motor
8	31513C	Cold Control
9	35768C	Cover - Relay
10	35900C	Power Cord
* 11	36094C	Compressor Serv. Pak EMI 70
12	36158C	Overload
13	35959C	Relay
14	50986C	Holder - Regulator
15	45866C	Bubbler
16	56092C	Tubing - Poly (Cut To length)
17	15005C	Retaining Nut
18	61313C	Regulator
19	66703C	Drier
20	66534C	Evaporator Assembly
21	70002C	Screw - #10 x 1/2" Lg. HHSM
22	70009C	Screw - Fan Motor
23	100147140560	Gasket - Drain
24	66723C	Tube - Evap to Base
25	28462C	Basin - Stainless Steel
26	22897C	Panel - Bottom Dispenser
27	45662C	Button - Push
28	45737C	Sleeve - Push Button
29	75672C	Cap Screw
30	160270508640	Strainer - Bright
31	600985451640	Plug - Drain 1-1/2CP
32	See Color Table	Panel - RH Rear
33	See Color Table	Panel - LH Rear
34	See Color Table	Panel - RH Dispenser Side
35	See Color Table	Panel - LH Dispenser Side
36	See Color Table	Panel - Dispenser Front
37	See Color Table	Panel - Front Lower
38	66743C	Condenser
39	56237C	Shroud Fan
40	40045C	Hex Nut
41	70018C	Hex Nut - Fan Blade
42	75524C	Clip (Front & Rear Panels)
43	55996C	Strainer (See "General Instructions")
44	45736C	Half Nut - Regulator
45	75570C	Screw - #10 x .50 Pinned Torx
46	75661C	Screw - #8 x .50 Pinned Torx
47	70864C	Screw - #8 x .62 Torx/Slot
48	56033C	Washer
49	66576C	Heat Exchanger
50	45351C	Wasteline
51	110868642550	Screw - #10 - 24 x .75 Socket Head
52	56121C	Drain Elbow
53	27124C	Cover - Cold Control
54	55931C	Cover - Dispenser Bottom
55	75588C	Nut - Slip Joint 1-1/4
56	28596C	Panel - Screen
57	28617C	Screen - VR
58	35906C	Heater Strip
59	35907C	Switch - Rocker
60	35909C	FR Thermostat Assy.
61	70432C	Screw - 8-32 x .38 THTC
62	75506C	Screw - #10 x .75 HHSM
Sold Separate	75520C	Torx Tool - T25
Sold Separate	75523C	Torx Tool - T20
NS	28551C	Hanger Bracket

*REPLACE WITH SAME COMPRESSOR USED IN ORIGINAL ASSEMBLY.

NOTE: All correspondence pertaining to any of the above water coolers or orders for repair parts MUST include Model No. and Serial No. of cooler, name and part number of replacement part.

Halsey Taylor

2222 CAMDEN COURT
OAK BROOK, IL 60523
630.574.3500

FOR PARTS CONTACT YOUR LOCAL DISTRIBUTOR OR VISIT OUR WEBSITE WWW.HALSEYTAYLOR.COM

PRINTED IN U.S.A.