

HALSEY TAYLOR OWNERS MANUAL

BI-LEVEL BARRIER FREE COOLER

USES HFC-134A REFRIGERANT

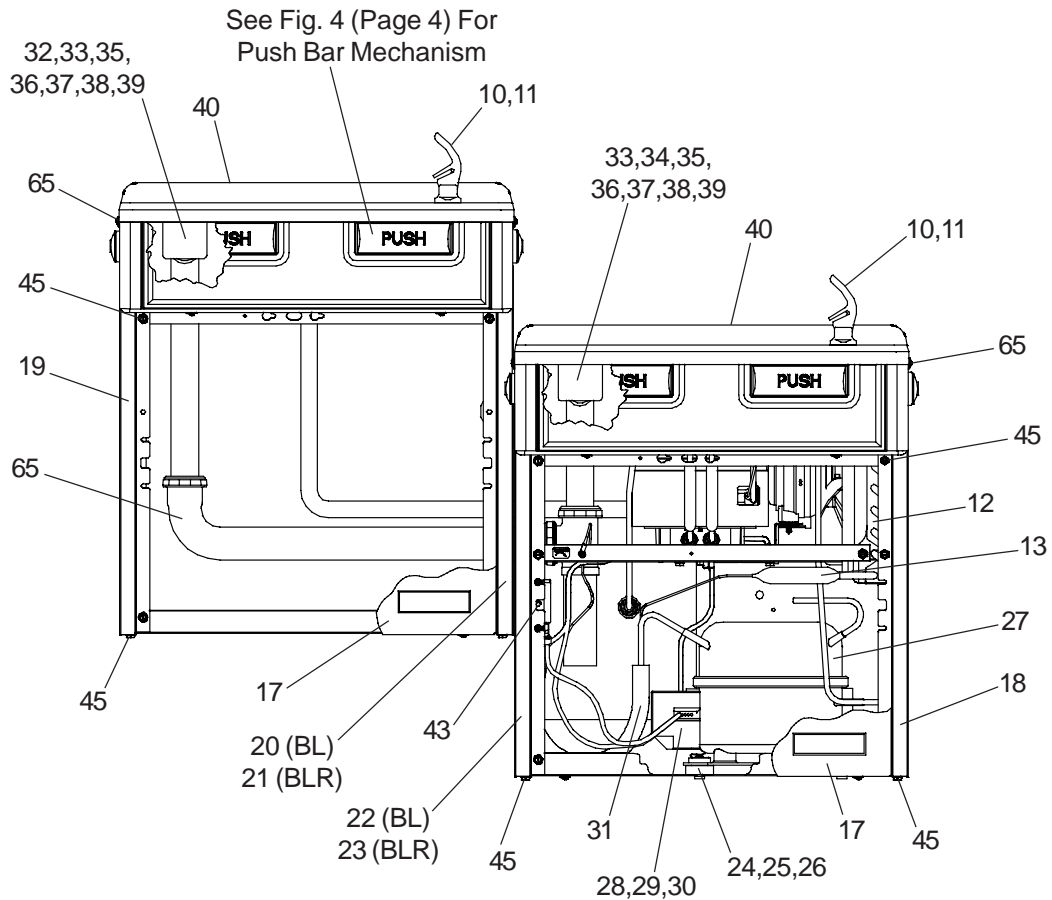
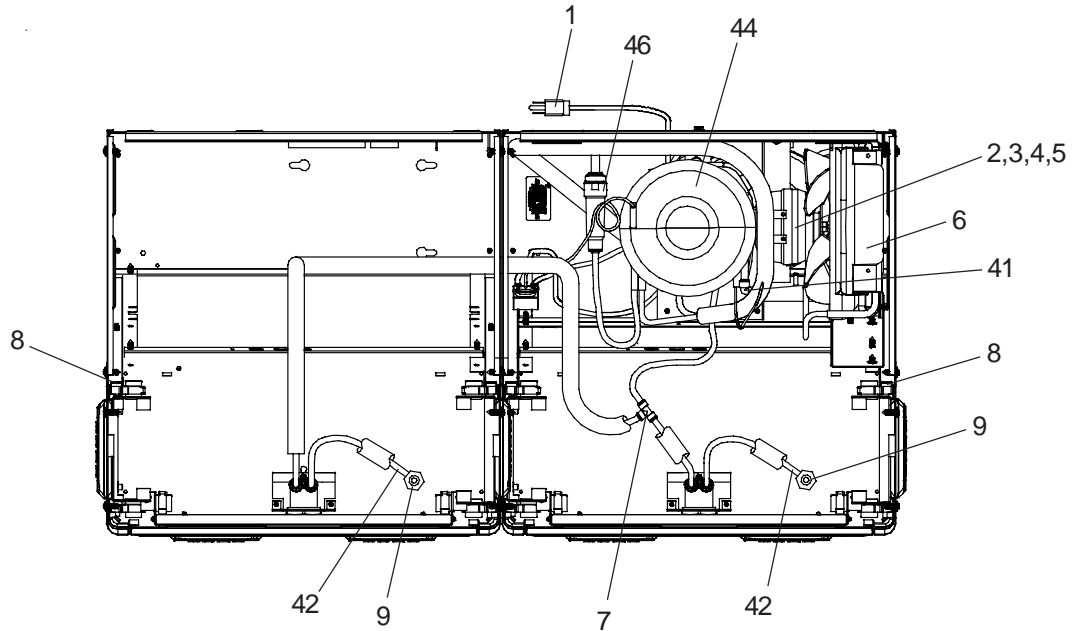

FIG. 1
HAC8FSCBL SHOWN

NOTE: Non-refrigerated units do not include all electrical and refrigeration components shown above. Other components and rough-in are the same as shown.

HAC8FSCBL

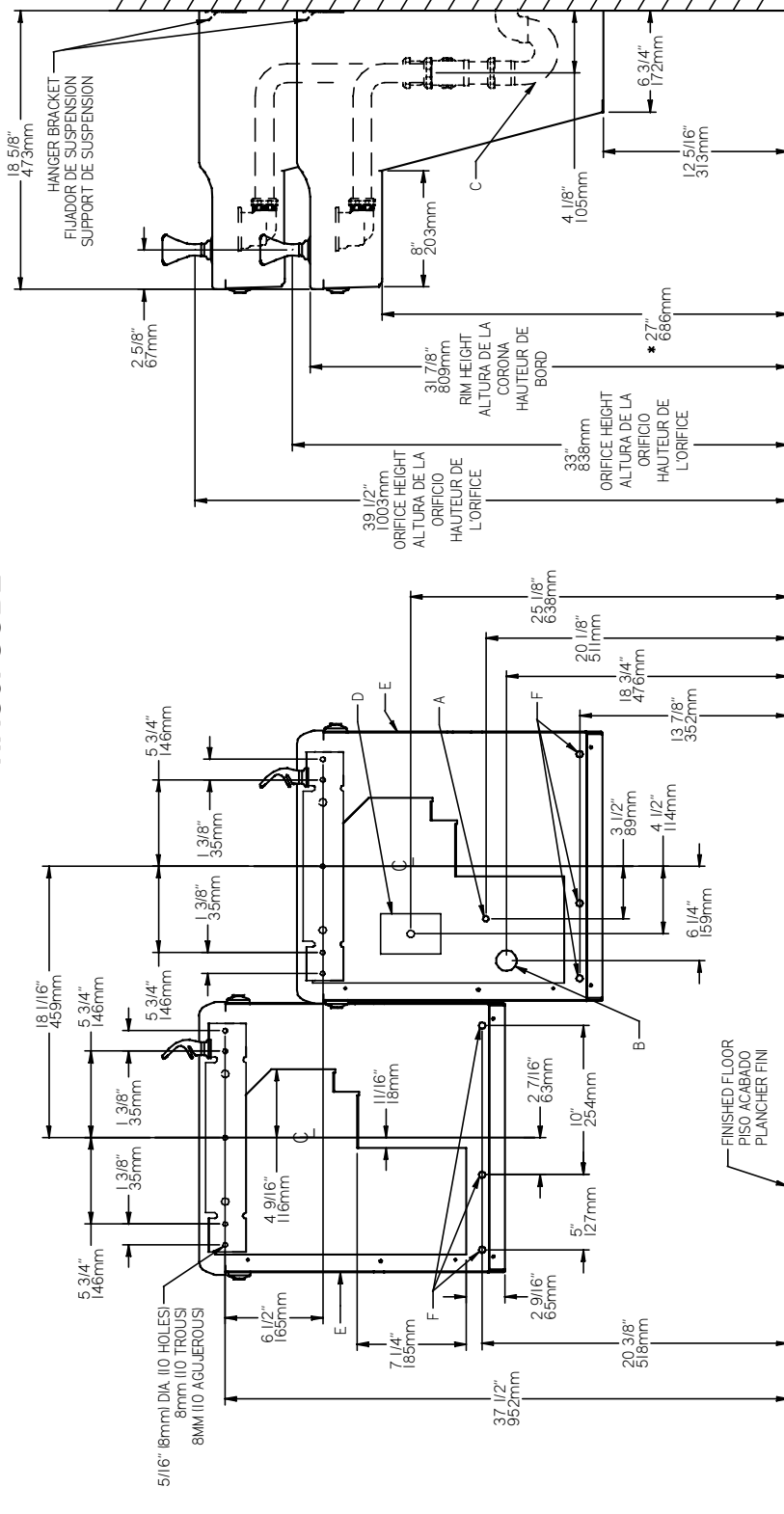

FIG. 2

REDUCE HEIGHT BY 3" FOR INSTALLATION OF CHILDRENS ADA COOLER

LEGEND/LEYENDA/LÉGENDE

- A = RECOMMENDED WATER SUPPLY LOCATION. SHUT OFF VALVE (NOT FURNISHED) TO ACCEPT 3/8 O.D. UNPLATED COPPER TUBE. POSICIÓN DE ABASTECIMIENTO DE AGUA RECOMENDADA. VÁLVULA CERRADA (NO AMUEBLADO) PARA ACEPTAR 3/8" O.D. TUBO DE COBRE NO PLATEADO. ENDROIT D'APPROVISIONNEMENT EN EAU RECOMMANDÉ. LA VALVE ARRÊTÉE (NON FOURNI) POUR ACCEPTER 3/8" PO. (9.5mm) TUBE COULLEUR. CUIVRE NON PLAQUÉ.
- B = RECOMMENDED LOCATION FOR WASTE OUTLET 1-1/2" O.D. DRAIN. UBICACIÓN RECOMENDADA PARA EL DRENAJE DE SALIDA DE AGUA. DE 1-1/2" DE DIÁMETRO. EMPLACEMENT RECOMMANDÉ POUR LE DRAIN DE D.E. 1-1/2" DE SORTIE D'EAU.
- C = 1-1/2" TRAP NOT FURNISHED* PURGADOR DE 1-1/2" NO PROPORCIONADO*
- D = ELECTRICAL SUPPLY (3) WIRE RECESSED BOX. CAJA RECESADA DE ALAMBRES (3) DE SUMINISTRO ELÉCTRICO. BOITE ENCASTRÉE D'ALIMENTATION ÉLECTRIQUE (3) FILS
- E = INSURE PROPER VENTILATION BY MAINTAINING 6" (152mm) (MIN.) CLEARANCE FROM CABINET LOUVERS TO WALL. ASEGURE UNA VENTILACIÓN ADECUADA MANTENIENDO UN ESPACIO E 6" (152mm) (MÍN.) ENTRE LES ÉVÉNENTS DE L'ENCEINTE ET LE MUR. ASSUREZ-VOUS UNE BONNE VENTILATION EN GARDANT 6" (152mm) (MÍN.) ENTRE LES ÉVÉNENTS DE L'ENCEINTE ET LE MUR.
- F = 7/16 BOLT HOLES FOR FASTENING UNIT TO WALL. AGUJEROS DE LAS TUERCAS DE 7/16 PARA SUJETAR LA UNIDAD A LA PARED. TROUS D'ÉCROUS 7/16 POUR FIXER L'APPAREIL AU MUR

* ADA REQUIREMENT
 * REQUISITO DE A.D.A.
 * EXIGENCE ADA

HAC8FSCBLR

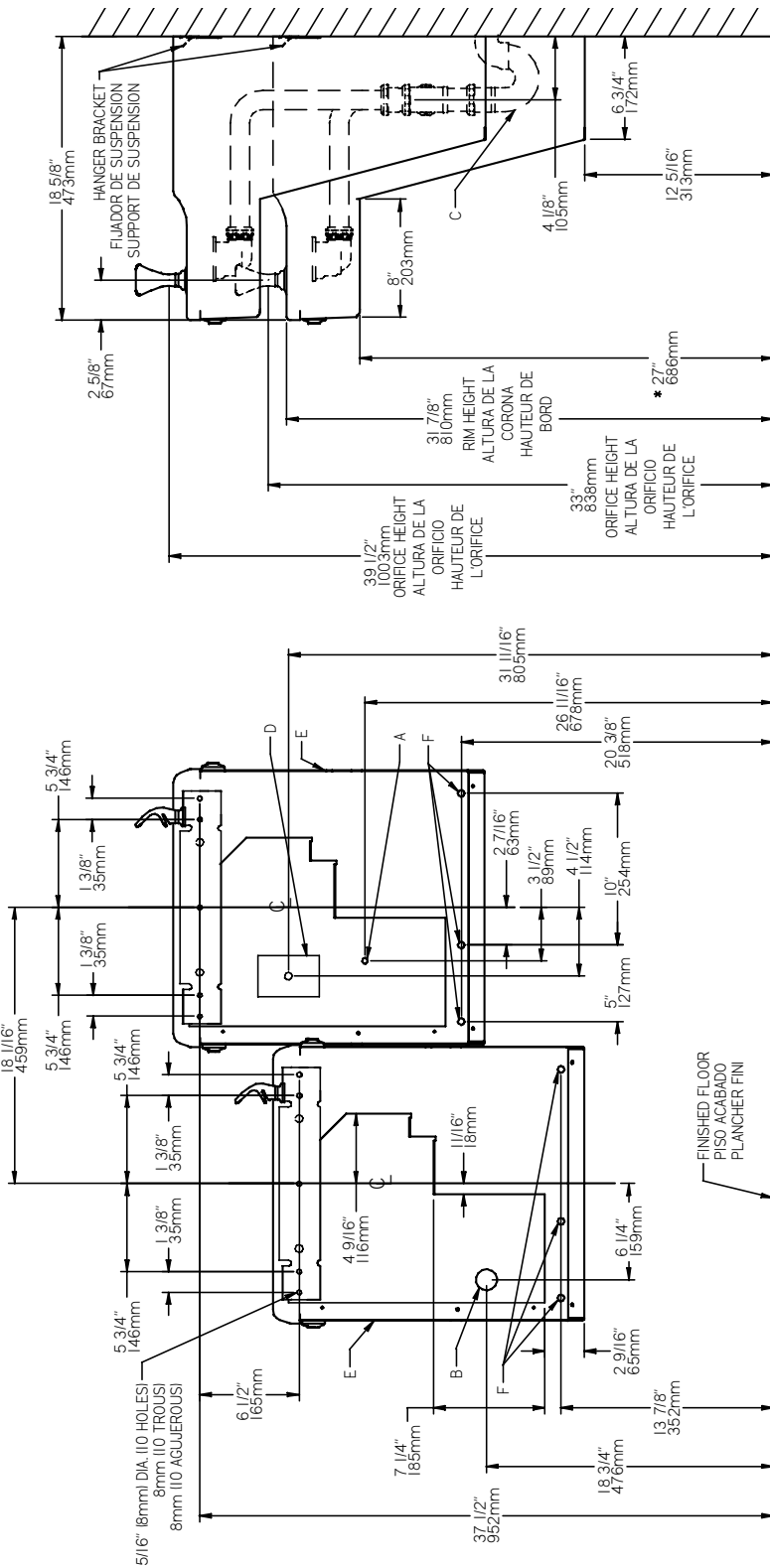

FIG. 3

REDUCE HEIGHT BY 3" FOR INSTALLATION OF CHILDRENS ADA COOLER

* ADA REQUIREMENT
 * REQUISITO DE A.D.A.
 * EXIGENCE ADA

LEGEND/LEYENDA/LÉGENDE

- A = RECOMMENDED WATER SUPPLY LOCATION. SHUT OFF VALVE (NOT FURNISHED) TO ACCEPT 3/8 O.D. UNPLATED COPPER TUBE. POSICIÓN DE ABASTECIMIENTO DE AGUA RECOMENDADA. VALVULA CERRADA (NO AMUEBLADO) PARA ACEPTAR 3/8" O.D. TUBO DE COBRE NO PLATEADO. ENDROIT D'APPROVISIONNEMENT EN EAU RECOMMANDÉ. LA VALVE ARRÊTÉE (NON FOURNI) POUR ACCEPTER 3/8" PO. (9,5mm)
- B = RECOMMENDED LOCATION FOR WASTE OUTLET 1-1/2" O.D. DRAIN. UBICACIÓN RECOMENDADA PARA EL DRENAJE DE SALIDA DE AGUA. DE 1-1/2 DE DIÁMETRO. EMPLACEMENT RECOMMANDÉ POUR LE DRAIN DE D.E. 1-1/2 DE SORTIE D'EAU.
- C = 1-1/2" TRAP NOT FURNISHED** PURGADOR DE 1-1/2 NO PROPORCIONADO**
- D = ELECTRICAL SUPPLY (3) WIRE RECESSED BOX. CAJA RECESADA DE ALAMBRES (3) DE SUMINISTRO ELÉCTRICO. BOÎTE ENCASTRÉE D'ALIMENTATION ÉLECTRIQUE (3) FILS
- E = INSURE PROPER VENTILATION BY MAINTAINING 6" (152 mm) (MIN.) CLEARANCE FROM CABINET LOUVERS TO WALL. ASEGURE UNA VENTILACION ADECUADA MANTENIENDO UN ESPACIO E 6" (152 mm) (MIN.) ENTRE LES ÉVENTS DE L'ENCEINTE ET LE MUR. ASSUREZ-VOUS UNE BONNE VENTILATION EN GARDANT 6" (152 mm) (MIN.) ENTRE LES ÉVENTS DE L'ENCEINTE ET LE MUR.
- F = 7/16 BOLT HOLES FOR FASTENING UNIT TO WALL. AGUJEROS DE LAS TUERCAS DE 7/16 PARA SUJETAR LA UNIDAD A LA PARED. TROUS D'ECROUS 7/16 POUR FIXER L'APPAREIL AU MUR

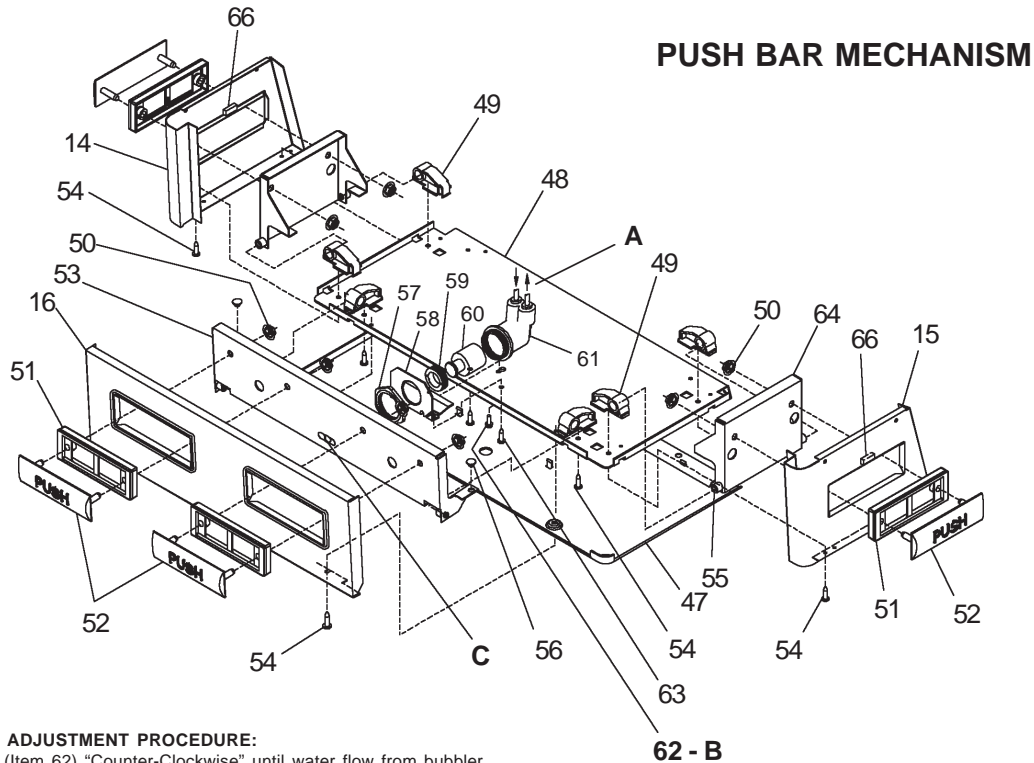

PUSH BAR MECHANISM

FIG. 4

Water Valve Mechanism - ADJUSTMENT PROCEDURE:

- Turn adjustment screw (Item 62) "Counter-Clockwise" until water flow from bubbler starts.
- Turn adjustment screw "Clockwise" until water flow stops, THEN turn an additional 1/2 turn.

NOTE: Adjustments stated above are viewed from underneath unit (bottom side of dispenser panel Item 48)

NOTE: If continuous flow occurs at the end of the compressor cycle, turn cold control (Item 43) counterclockwise 1/4 turn.

LEGEND

- A) Note: Water flow direction
- B) Adjust this screw to eliminate mechanism "Free Play" or continuous flow from bubbler conditions. (See ADJUSTMENT PROCEDURE)
- C) Stream height adjustment (see note #8)

IMPORTANT
ALL SERVICE TO BE PERFORMED BY AN
AUTHORIZED SERVICE PERSON

HANGER BRACKETS & TRAP
INSTALLATION

- 1) Remove hanger brackets fastened to back of cooler by removing one (1) screw.
 - 2) Mount the hanger brackets and trap as shown in Figures 2 or 3.
- NOTE:** Hanger Brackets **MUST** be supported securely. Add fixture support carrier if wall will not provide adequate support.

IMPORTANT:

- 4 1/8 in. (105mm) dimension from wall to centerline of trap must be maintained for proper fit.
 - Anchor hanger securely to wall using all five (5) 5/16" dia. mounting holes.
- 3) Install straight valve for 3/8" O.D. tube.

INSTALLATION OF COOLER

- 4) Hang the cooler on the hanger bracket. Be certain the hanger bracket is engaged properly in the slots on the cooler back as shown in Fig. 5.
- 5) Loosen the two (2) screws holding the lower front panel at the bottom of cooler base and two (2) screws at the top. Remove the front panel and set aside.
- 6) Connect water inlet line--See Note 4 of General Instructions.
- 7) Remove the slip nut and gasket from the trap and install them on the cooler waste line making sure that the end of the waste line fits into the trap. Assemble the slip nut and gasket to the trap and tighten securely.

START UP

Also See General Instructions

- 8) Stream height is factory set at 45-50 PSI. If supply pressure varies greatly from this, readjust stream height to approximately 1-1/2" (38mm) above the bubbler guard by turning adjustment screw, accessible by removing front push panel. Item No. 16 (see Fig. 4 & 6).
- 9) Replace the front panel and secure by retightening four (4) screws.
- 10) If a taste, odor or sediment problem is prevalent, try installing our water filter module.

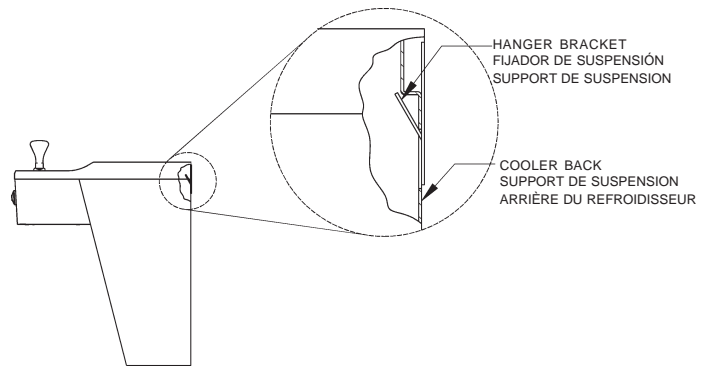
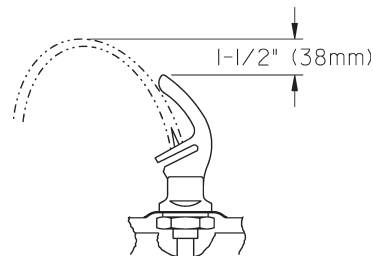

FIG. 5



CORRECT STREAM HEIGHT

FIG. 6

ITEMIZED PARTS LIST

ITEM NO	PART NO	DESCRIPTION
1	36208C	Power Cord
2	30664C	Fan Blade
3	70018C	Hex Nut - Fan Blade
4	31490C	Fan Motor
5	70009C	Screw - (Fan Motor)
6	56237C	Shroud - Fan
7	70682C	Fitting - Tee 1/4"
8	75524C	Clip (Front and Rear Panels)
9	56159C	Nipple - Bubbler
10	51544C	Bubbler - Chrome
11	100322740560	Gasket - Bubbler (upper and lower)
12	66743C	Condenser
13	66703C	Drier
14	See Color Table	Panel - Left Side
15	See Color Table	Panel - Right Side
16	See Color Table	Panel - Front Push
17	See Color Table	Panel - Front Lower
18	See Color Table	Panel - Right Rear
19	See Color Table	Panel - Left Rear
20	See Color Table	Panel - Right Rear BL
21	See Color Table	Panel - Right Rear BLR
22	See Color Table	Panel - Left Rear BL
23	See Color Table	Panel - Left Rear BLR
24	101474551730	Stud - Compressor Mtg.
25	100806740570	Grommet - Compressor Mtg.
26	19037000	Clip - Compressor Mtg.
*27	36094C	Compressor Serv. Pak EMI 70 HNR
28	35959C	Relay
29	35768C	Cover - Relay
30	36158C	Overload
31	66576C	Heat Exchanger
32	45895C	Waste Line BL (Left Unit)
32A	45895C	Waste Line BLR (Left Unit)
33	75589C	Gasket
34	45895C	Waste Line BL (Refrig. Unit)
34A	45895C	Waste Line BLR (Refrig. Unit)
35	56121C	Fitting - Elbow 1-1/4
36	75588C	Nut - Slip Joint 1-1/4
37	100147140560	Gasket - Drain
38	102639931640	Drain Plug - Chrome
39	160270508640	Strainer Plate - Chrome
40	28702C	Basin - Stainless Steel
41	75583C	Elbow - 5/16" x 1/4"
42	56092C	Tubing - Poly (Cut To Length)
43	31513C	Cold Control
44	66534C	Evaporator Assembly
45	70002C	Screw - #10 x 1/2" Lg. HHSM
46	55996C	Strainer
47	55931C	Cover - Dispenser Bottom
48	22897C	Panel - Bottom Dispenser
49	51531C	Block - Pivot
50	111411743620	Nut - 1/4, Self-Threading
51	55859C	Pushbar - Side & Front
52	55947C	Insert - Push Bar, Gray
53	22900C	Bracket - Front Push
54	70864C	Screw - #8 x 5/8" Lg. Torx/Slot
55	50212C	Rivet - Drive Type
56	51667C	Bumper - Press Bar
57	40045C	Hex Nut
58	23003C	Bracket - Regulator Mounting
59	15005C	Retaining Nut
60	61314C	Regulator
61	50986C	Holder - Regulator
62	70935C	Screw - Shoulder x 1/2" Lg.
63	75532C	Screw - #10-16 x .63 THSM
64	22901C	Bracket - Side Push
65	45876C	Drain Tube Assembly
66	50129C	Bumper
NS	28551C	Hanger Bracket

Refrig. Unit	COLOR TABLE							
	Panel Color	Item No. 14 Part No.	Item No. 15 Part No.	Item No. 16 Part No.	Item No. 17 Part No.	Item No. 18 Part No.	Item No. 22 Part No.	Item No. 23 Part No.
	Platinum Vinyl	28127C	28123C	28705C	22844C	28144C	28161C	28712C
Stainless Steel	28128C	28124C	28706C	22955C	28525C	28536C	28562C	

Left Unit	COLOR TABLE							
	Panel Color	Item No. 14 Part No.	Item No. 15 Part No.	Item No. 16 Part No.	Item No. 17 Part No.	Item No. 19 Part No.	Item No. 20 Part No.	Item No. 21 Part No.
	Platinum Vinyl	28127C	28123C	28705C	22844C	28148C	28709C	28715C
Stainless Steel	28128C	28124C	28706C	22955C	28528C	28539C	28559C	

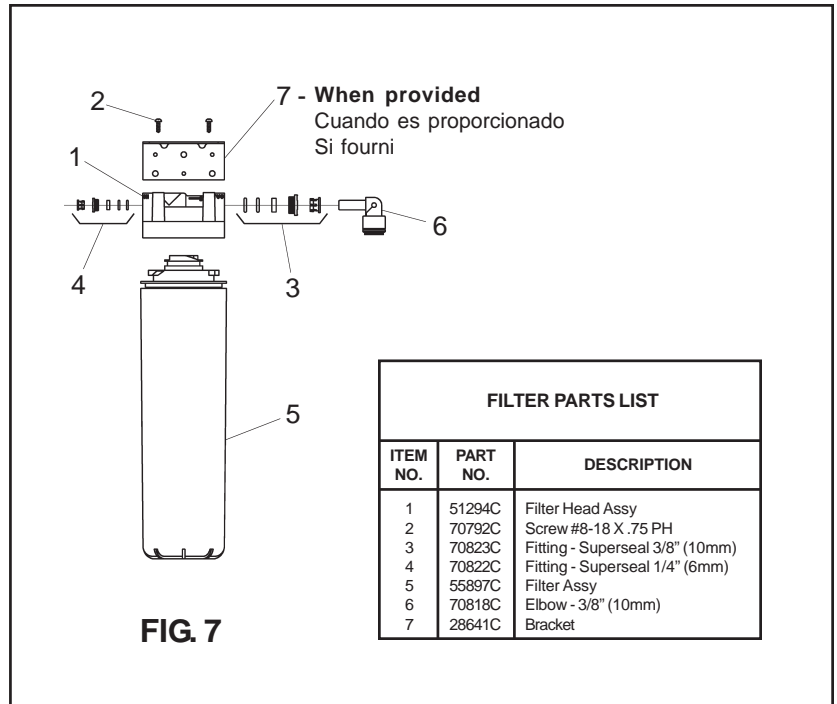

FILTER PARTS LIST		
ITEM NO.	PART NO.	DESCRIPTION
1	51294C	Filter Head Assy
2	70792C	Screw #8-18 X .75 PH
3	70823C	Fitting - Superseal 3/8" (10mm)
4	70822C	Fitting - Superseal 1/4" (6mm)
5	55897C	Filter Assy
6	70818C	Elbow - 3/8" (10mm)
7	28641C	Bracket

***REPLACE WITH SAME COMPRESSOR USED IN ORIGINAL ASSEMBLY.**

NOTE: All correspondence pertaining to any of the above water coolers or orders for repair parts MUST include Model No. and Serial No. of cooler, name and part number of replacement part.

Halsey Taylor

2222 CAMDEN COURT
 OAK BROOK, IL 60523
 630.574.3500

PRINTED IN U.S.A.

FOR PARTS CONTACT YOUR LOCAL DISTRIBUTOR OR VISIT OUR WEBSITE - WWW.HALSEYTAYLOR.COM