



# Water Coolers

## RADII™ FOUNTAIN

### F140REE

#### Suggested Specification

Model F140REE shall include infrared sensors to activate the flow of water. Fountain shall be designed to eliminate splashing and standing water. Bubbler shall have flexible guard and operate between 20 and 120 PSI. Drinking water coolers shall comply with ANSI A117.1-1992 and ADA frontal approach requirements. Listed by Underwriters' Laboratories to U.S. and Canadian standards. Shall comply with the Safe Drinking Water Act and Lead Contamination Control Act. Shall comply with ANSI/NSF 61. RADII™ Modular Fountain meets the needs of the physically challenged and the able-bodied.

#### Model

**F140REE** A reflective light beam activates the fountain when the user approaches. No touching or pushing is needed. The system features a time delay to avoid unwanted activation and a shut off if the user does not move away in 30 seconds.

#### Standard Features

- > Built-in 100 micron strainer stops particles before they enter the waterway
- > Flexible bubbler guard
- > Waterways are Lead-Free in Materials & Construction
- > Brushed Stainless Steel Finish
- > Product Certified to NSF/ANSI Standard 61, Annex G (AB1953)
- > Limited 1-Year Warranty

#### Finishes

- > Standard Cabinet Finish: Stainless Steel
- > Optional Cabinet Finish (at additional cost): Regency Bronze

#### Installation

- > Prior to roughing-in, consult local, state and federal codes for proper mounting height.

#### Options (at additional cost)

- > Stainless Steel Bubbler

#### Weight

- > Net weight approximately 19 lbs.



ADA Compliant when installed in an alcove or with right and left wing walls.



Components in this fountain are lead free as defined by the Safe Drinking Water Act Amendments of 1986, and the Lead Contamination Control Act of 1988.

**Limited 1-Year Warranty** (Continental limits of the United States and Canada): One year from date of installation on parts only. Detailed warranty certificate enclosed with each drinking fountain; sample copy available upon request.

**Export Warranty:** One year on component parts. Detailed warranty certificate enclosed with each drinking fountain; sample copy available upon request.

Product Certified to NSF/ANSI Standard 61, Annex G (weighted average lead content of  $\leq 0.25\%$ ) and is in compliance with California's Health & Safety Code Section 116875 (commonly known as AB1953).

Models covered by this specification comply with all known Plumbing Codes. Drinking water coolers shall comply with ANSI A117.1-1992 and ADA frontal approach requirements. Listed by Underwriters' Laboratories to U.S. and Canadian standards.

Water Coolers are classified by Underwriters Laboratories Inc. in accordance with ANSI/NSF 61.



Certified to NSF/ANSI 61-G

# OASIS™ RADII™ BARRIER-FREE DRINKING FOUNTAIN F140REE

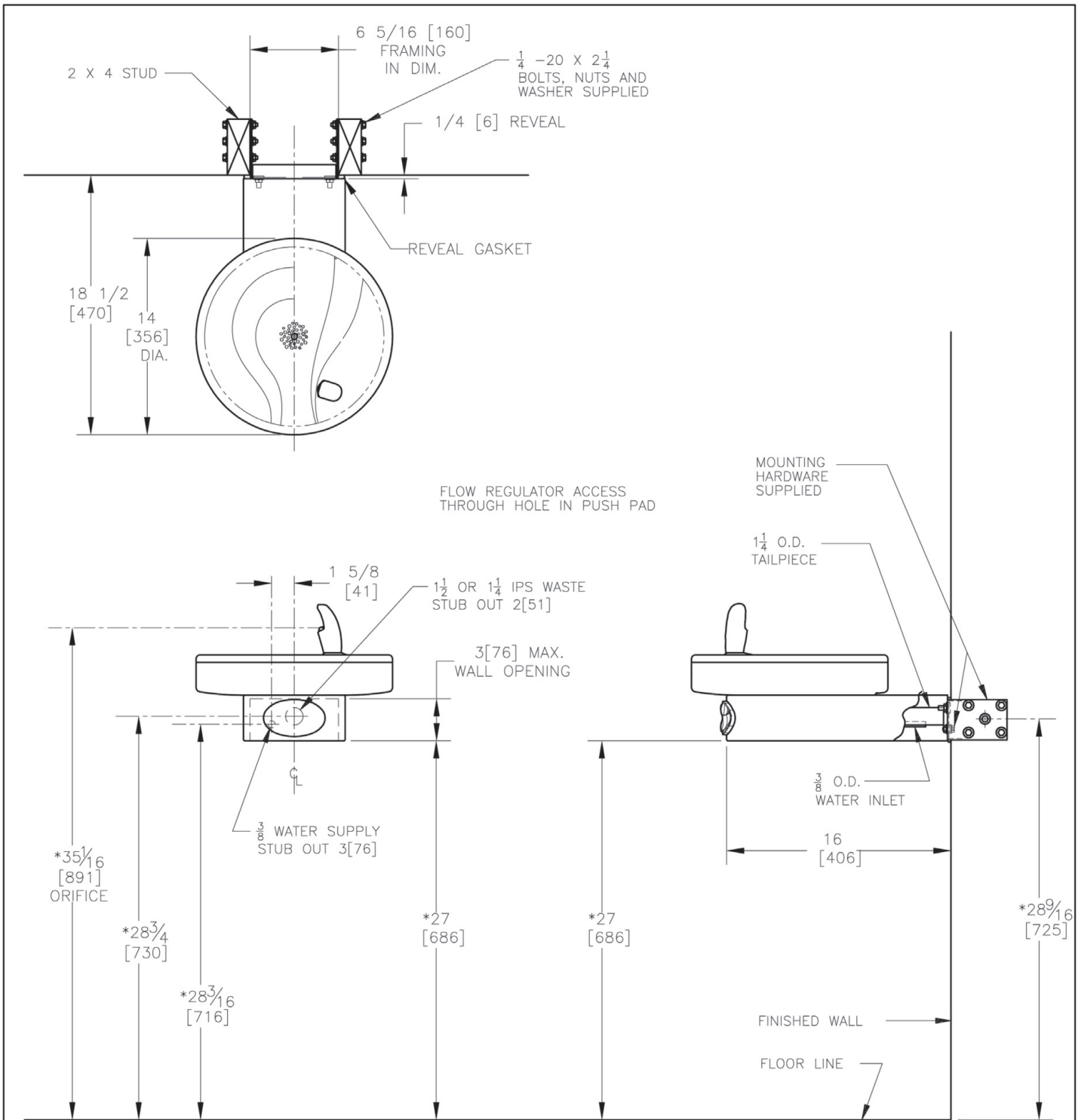

**NOTES:**

- \*1. RECOMMENDED ADULT HEIGHT INSTALLATION SHOWN. ADJUST VERTICAL DIMENSIONS AS REQUIRED TO COMPLY WITH FEDERAL, STATE AND LOCAL CODES.
- 2. STOP VALVE, TRAP, PIPE CONNECTOR TO WASTE LINE AND  $\frac{3}{8}$  COMP. FITTING NOT PROVIDED.
- 3. ALL DIMENSIONS ARE IN INCHES. DIMENSIONS IN BRACKETS [ ] ARE IN MILLIMETERS.

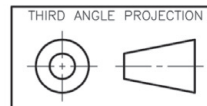

ROUGHING-IN AND DIMENSIONAL DRAWING