

Halsey Taylor Owners Manual

Fully-Recessed Non-Refrigerated Fountain

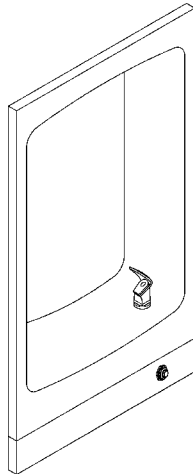

INSTALLER

To assure you install these models easily and correctly, PLEASE READ THESE SIMPLE INSTRUCTIONS BEFORE STARTING THE INSTALLATION. CHECK YOUR INSTALLATION FOR COMPLIANCE WITH PLUMBING, ELECTRICAL, AND OTHER APPLICABLE CODES. After installation, leave these instructions with the Fountain for future reference.

IMPORTANT

ALL SERVICE TO BE PERFORMED BY AN AUTHORIZED SERVICE PERSON

IMPORTANT! INSTALLER PLEASE NOTE.

THE GROUNDING OF ELECTRICAL EQUIPMENT SUCH AS TELEPHONE, COMPUTERS, ETC. TO WATER LINES IS A COMMON PROCEDURE. THIS GROUNDING MAY BE IN THE BUILDING OR MAY OCCUR AWAY FROM THE BUILDING. THIS GROUNDING CAN CAUSE ELECTRICAL FEEDBACK INTO A FOUNTAIN, CREATING AN ELECTROLYSIS WHICH CAUSES A METALLIC TASTE OR AN INCREASE IN THE METAL CONTENT OF THE WATER. THIS CONDITION IS AVOIDABLE BY USING THE PROPER MATERIALS AS INDICATED. ANY DRAIN FITTINGS PROVIDED BY THE INSTALLER SHOULD BE MADE OF PLASTIC TO ELECTRICALLY ISOLATE THE FOUNTAIN FROM THE BUILDING PLUMBING SYSTEM.

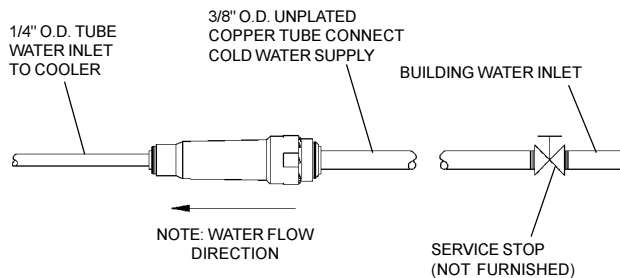

FIG. 1

OPERATION OF QUICK CONNECT FITTINGS

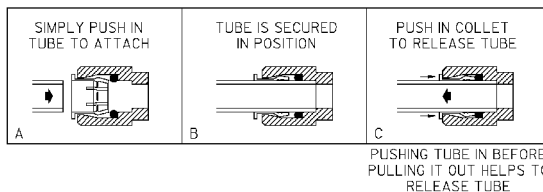
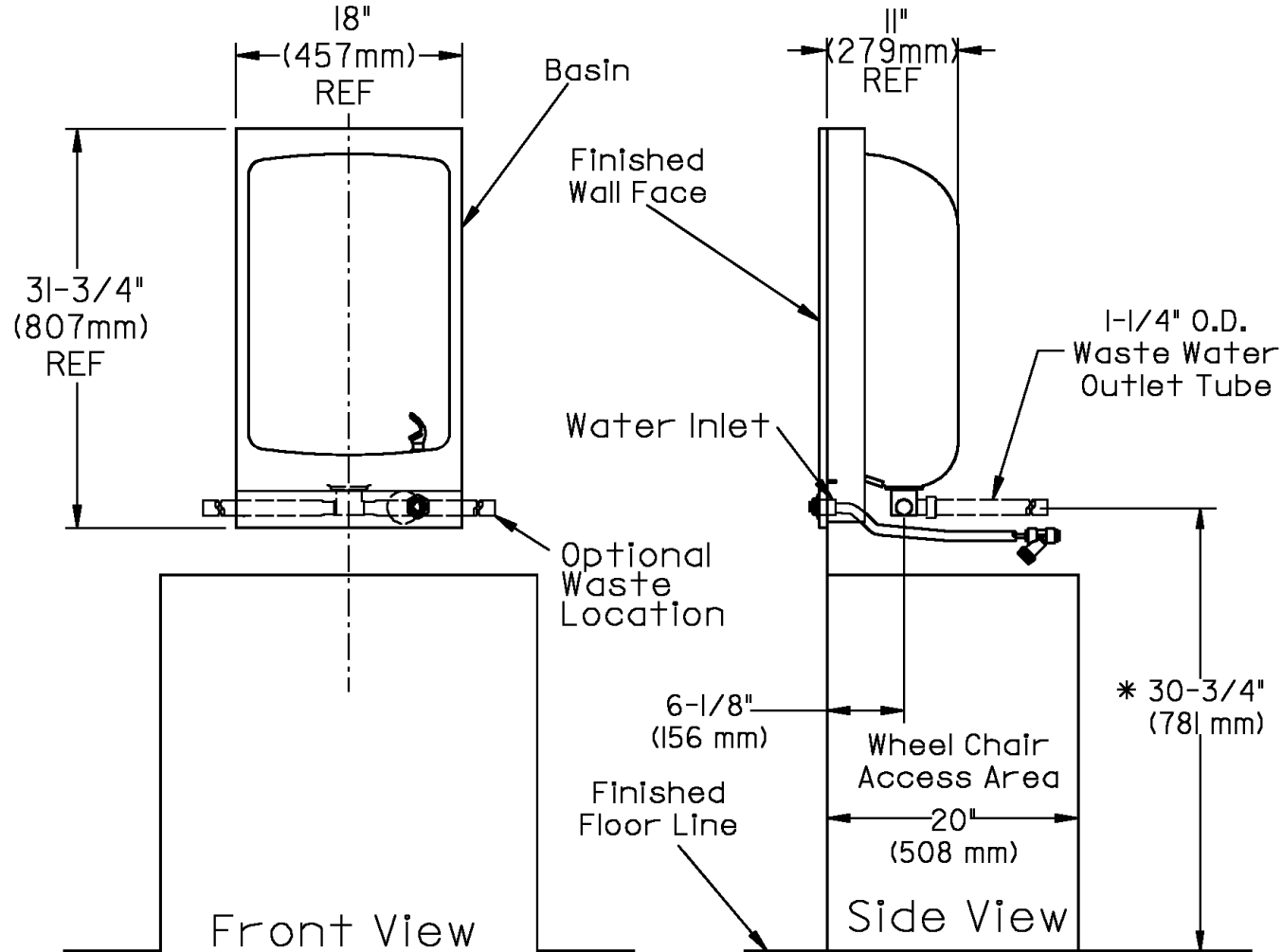

FIG. 2

ROUGH-IN DIMENSIONS



* NOTE: If wall opening height has been adjusted to meet local codes (see wallframe instructions), height dimensions must be adjusted accordingly.

FIG. 3

WALLFRAME INSTALLATION INSTRUCTIONS

BEFORE STARTING THE INSTALLATION, PLEASE CHECK YOUR INSTALLATION FOR COMPLIANCE WITH PLUMBING, ELECTRICAL AND OTHER APPLICABLE CODES

At 30" above the finished floor, cut a rectangular wall opening 17-1/8" wide by 30-1/8" high. This is required to obtain a rim height of 34-1/2" and 36" bubbler spout height, which is in compliance with ANSI Standard A117.1 (See Fig. 4)

Reinforce wall opening on all sides so that it will adequately support the water cooler. IT MUST SUPPORT UP TO 150 LBS. and provide a means of securing the frame assembly in place.

Install rough-in plumbing. See Fig. 3 for location of supply water inlet and for location of waste water outlet.

Install frame assembly in the wall opening with front edge flush with finished wall face. Secure frame through holes in top and sides to wall support members with 5/16" diameter bolts or lag screws (not supplied). Six (6) bolts/screws are required. CAUTION: BE SURE THAT FRAME ASSEMBLY IS SQUARED IN ITS LOCATION AND DO NOT USE LESS THAN REQUIRED QUANTITY AND DIAMETER OF THE FASTENERS.

WALL ROUGH-IN

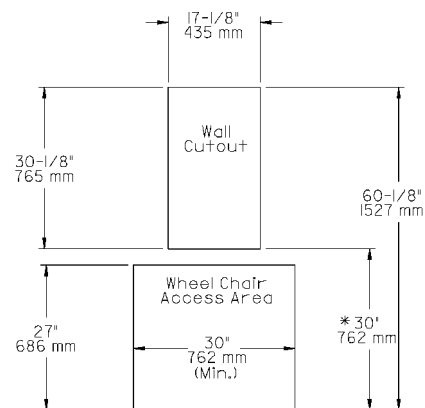

* 30" (762 mm) to bottom of wall cutout required to obtain 34-1/2" (876 mm) rim height (Check local codes).

FIG. 4

INSTALLATION INSTRUCTIONS

1. Familiarize yourself with the wallbox which should already be placed in the wall. If not, refer to the "Wall frame" Installations before proceeding.
2. Remove noise pad from paper and locate on bottom back of the basin between the drain and the bubbler holes.
CAUTION: TO INSURE PAD DOES NOT INTERFERE WITH THE HOLE AREAS, TRIM THE PAD SO THERE IS APPROX. 1/2" CLEARANCE AROUND THE HOLES.
3. Determine location of rough plumbing.
4. Attach basin mounting brackets to basin studs located in the lower corners with two (2) provided wing nuts. Tighten securely.
5. Install basin. Place the upper edge of basin above the hangers in the wall frame. Slide the basin down until it engages the hanger. Be sure basin is firmly engaged before releasing it.
6. Finish securing basin in place through the mounting bracket using the provided two (2) #8 x 3/4" tap screws and two (2) 11/64" ID washers. Tighten securely.
7. Install waste tube assembly. Align threaded portion of drain tube assembly with the drain hole in the basin. Place rubber gasket between the drain assembly and the basin, then screw in the drain plug from above. Tighten the drain plug. Snap the strainer plate into the drain plug.
8. Install a service stop (not provided) on supply inlet line.
9. Make connection from water outlet to regulator valve assembly using the provided strainer. Insert water line in inlet side of strainer (see Figures 1 and 2) to positive stop - approximately 3/4" (19 mm). **DO NOT SOLDER TUBES INSERTED INTO THE STRAINER AS DAMAGE TO THE O-RINGS MAY RESULT.**
10. Open service stop and operate push button to purge air from system. Check thoroughly for leaks. Check stream height from bubbler. Stream height is factory set at 45-50 PSI. If supply pressure varies greatly from this, remove items 17 and 18 and adjust screw on regulator (item 14). Clockwise adjustment will raise stream and CCW adjustment will lower stream height. For best adjustment stream height should be approximately 1-1/2" (38 mm) above the bubbler guard. (See Figure 6).
11. Attach regulator housing (Item 13) to front panel (Item 3) with hex nut (Item 16). Install front panel. Hold panel and engage angle on top edge of panel with lower edge of basin. Swing bottom of panel into place against the wall and secure using panel mounting screws.

ITEMIZED PARTS LIST

ITEM NO.	PARTNO.	DESCRIPTION
1	170857042830	Basin - Stainless Steel
	410857042450	Basin - Golden Bronzestone
2	734253251550	Mounting Frame
3	23021C	Front Panel - Stainless Steel
	23022C	Front Panel - Golden Bronzestone
4	62257C	Tube - Regulator In
5	100147140560	Gasket
6	160270508650	Strainer Plate - Chrome
	410270508450	Strainer Plate - Golden Bronzestone
7	161637308640	Drain Plug - Chrome
	411637308450	Drain Plug - Golden Bronzestone
8	51546C	Bubbler - Chrome
	45397C	Bubbler - Golden Bronzestone
9	100322740560	Gasket - Bubbler (2-Req'd)
10	62300C	Tube Assy - Bubbler
11	66346C	Tube - Waste
11a	75588C	Nut - Slip Joint 1-1/4
11b	55884C	Elbow - Drain
12	74050011	Noise Pad
13	50986C	Holder Regulator
14	61313C	Regulator
15	15005C	Retaining Nut
16	40169C	Hex Nut - Chrome
	40170C	Hex Nut - Golden Bronzestone
17	40089C	Cover Nut - Chrome
	40119C	Cover Nut - Golden Bronzestone
18	40048C	Button - Chrome
	40065C	Button - Golden Bronzestone
19	55996C	Strainer

TROUBLE SHOOTING AND MAINTENANCE

CAUTION: Cleaning of Golden Bronzestone Models requires special care. Outer surfaces must be cleaned with a mild detergent or mixture of vinegar and water only, rinsed and wiped dry. Abrasive and acidic cleaners may eventually damage the Golden Bronzestone finish.

Orifice Assy: Mineral deposits on orifice can cause water flow to spurt or not regulate. Mineral deposits may be removed from the orifice with a small round file not over 1/8" diameter or small diameter wire. **CAUTION: DO NOT** file or cut orifice material.

Stream Regulator: If orifice is clean, regulate flow as in instructions. If replacement is necessary, see parts list for correct regulator part number.

Actuation of Quick Connect Water Fittings: Cooler is provided with lead-free connectors which utilize an o-ring water seal. To remove tubing from the fitting, relieve water pressure, push in on the gray collar while pulling on the tubing.(see Fig.2) To insert tubing, push tube straight into fitting until it reaches a positive stop, approximately 3/4".

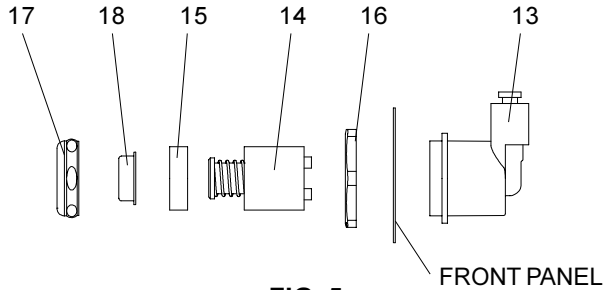
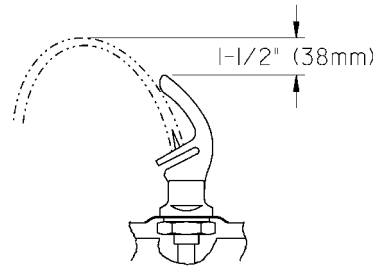

FIG. 5



CORRECT STREAM HEIGHT

FIG. 6

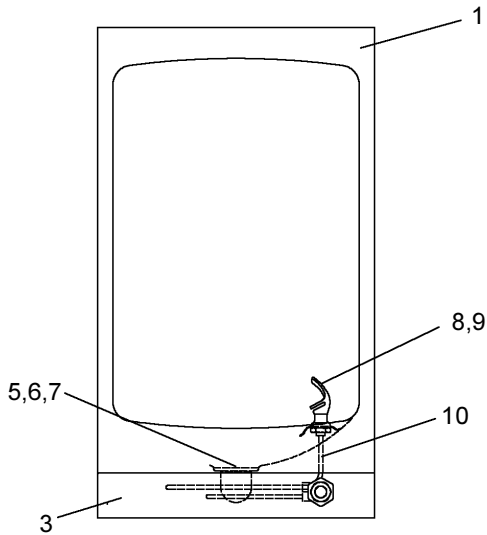
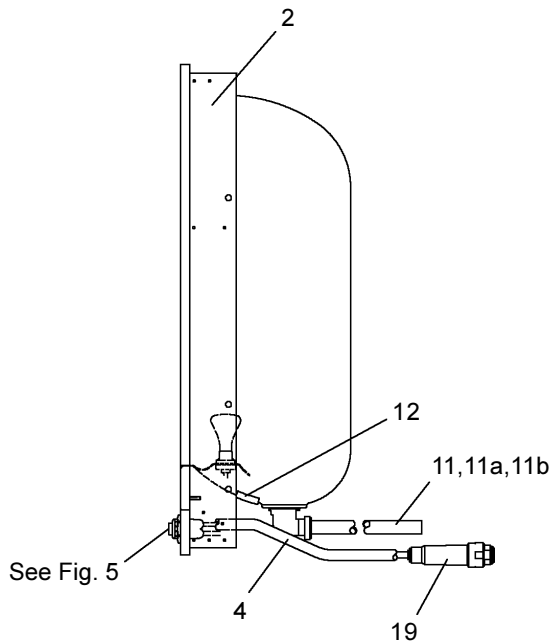

FIG. 7



Halsey Taylor
 2222 CAMDEN COURT
 OAKBROOK, IL 60523
 630.574.3500
 PRINTED IN U.S.A.

FOR PARTS, CONTACT YOUR LOCAL DISTRIBUTOR OR CALL 1.800.323.0620