

# Halsey Taylor Owners Manual

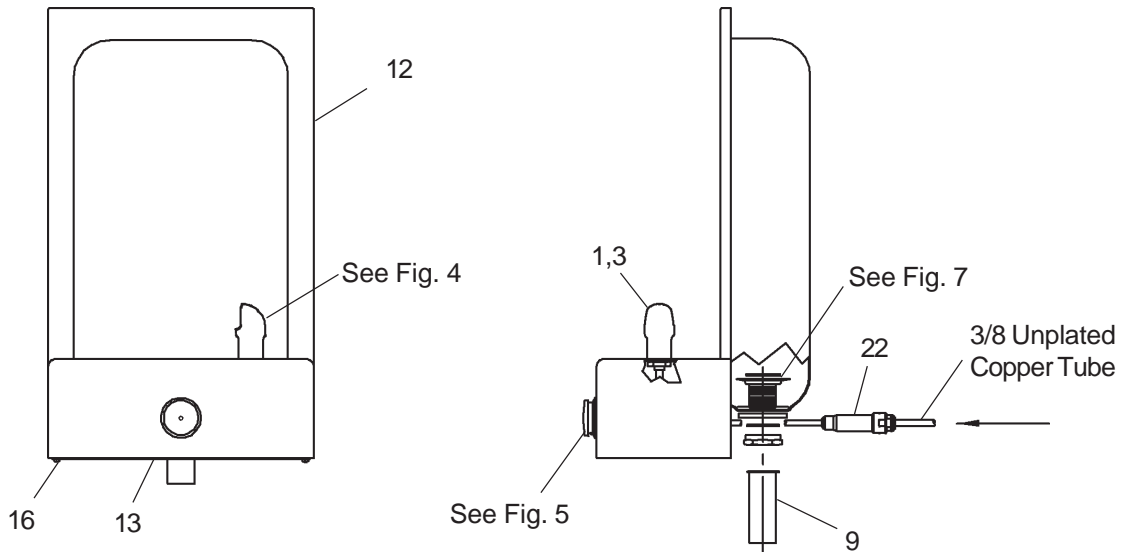

## INSTALLER

Halsey Taylor Fountains are among the easiest to install Fountains on the market today. To assure you install these models easily and correctly, PLEASE READ THESE SIMPLE INSTRUCTIONS BEFORE STARTING THE INSTALLATION. CHECK YOUR INSTALLATION FOR COMPLIANCE WITH PLUMBING, ELECTRICAL, AND OTHER APPLICABLE CODES. After installation, leave these instructions with the Fountain for future reference.

### IMPORTANT

ALL SERVICE TO BE PERFORMED BY AN AUTHORIZED SERVICE PERSON

### IMPORTANT! INSTALLER PLEASE NOTE.

THE GROUNDING OF ELECTRICAL EQUIPMENT SUCH AS TELEPHONE, COMPUTERS, ETC. TO WATER LINES IS A COMMON PROCEDURE. THIS GROUNDING MAY BE IN THE BUILDING OR MAY OCCUR AWAY FROM THE BUILDING. THIS GROUNDING CAN CAUSE ELECTRICAL FEEDBACK INTO A FOUNTAIN, CREATING AN ELECTROLYSIS WHICH CAUSES A METALLIC TASTE OR AN INCREASE IN THE METAL CONTENT OF THE WATER. THIS CONDITION IS AVOIDABLE BY USING THE PROPER MATERIALS AS INDICATED. ANY DRAIN FITTINGS PROVIDED BY THE INSTALLER SHOULD BE MADE OF PLASTIC TO ELECTRICALLY ISOLATE THE FOUNTAIN FROM THE BUILDING PLUMBING SYSTEM.



# 5801VR\*C FOUNTAIN

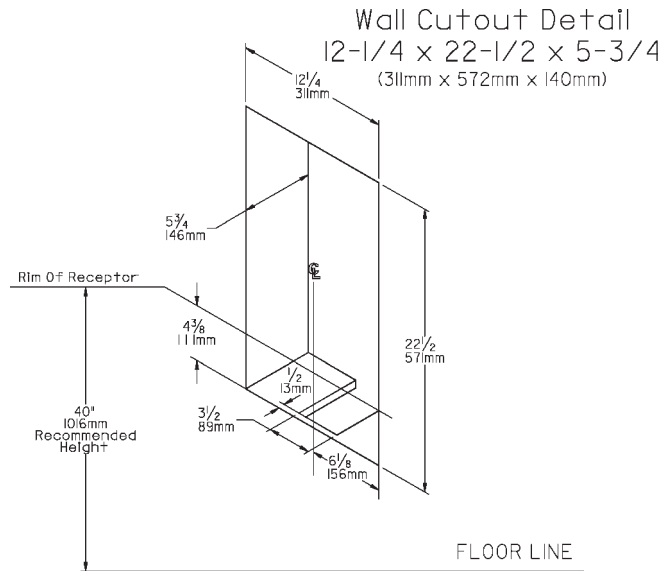

FIG. 2

## INSTALLATION INSTRUCTIONS

1. Prepare the wall cutout opening(s). Refer to Wall Cutout Detail (See Fig. 2).
2. Prepare waste connection(s) and water supply hookup connection. Refer to roughin drawing for location details (See Fig. 1).  
**NOTE:** Access to the rear of the fountain is desirable to ease installation. If rear access is not obtainable an access panel (furnished by others) should be installed below the fountain.
3. Install the fountain hanger bracket(s) to the upper edge of the wall cutout. Remove bottom cover plates from the fountain. Save the cover plates and screws for reinstallation.
4. Install the basin. Place the upper edge of the basin above the hanger in the wall frame. Slide the basin down until it engages the hanger. Be sure the basin is firmly engaged before releasing it. Secure the bottom of the fountain to the wall frame. If fountain is used with the 5803 Cuspidor repeat above steps.  
**NOTE: SCREWS FOR ATTACHING THE FOUNTAIN HANGER BRACKET AND BASIN ARE NOT INCLUDED.**
5. Connect waste line traps to the fountain (and cuspidor if required). Connect water supply line service stop to the water inlet line on the 5801 Fountain. Fountain is supplied with a 3/8" unplated copper water hookup line with a strainer. The fountain must be connected through the strainer to eliminate damage to the water regulator on/off control.  
**NOTE: WASTELINE TRAP(S) AND SERVICE SUPPLY STOPS ARE NOT INCLUDED.**
6. 5803 Cuspidor only. Connect outlet of the check valve to the inlet line, to the sprayer head, on the 5803 Cuspidor. Check valve flow direction must be as shown for correct operation.
7. Open service stop and operate push button to purge air from system. Check thoroughly for leaks. Check stream height from bubbler. Stream height is factory set at 45-50 PSI. If supply pressure varies greatly from this, adjust the screw on regulator item 21 by using a small screwdriver through the small hole in the push button item 15 (See Fig.5). Clockwise adjustment will raise stream and CCW adjustment will lower stream height.
8. Assemble cover plate to bottom of fountain with screws supplied.

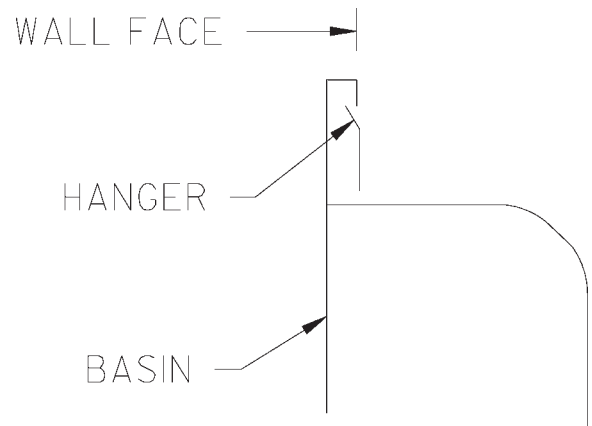

FIG. 3

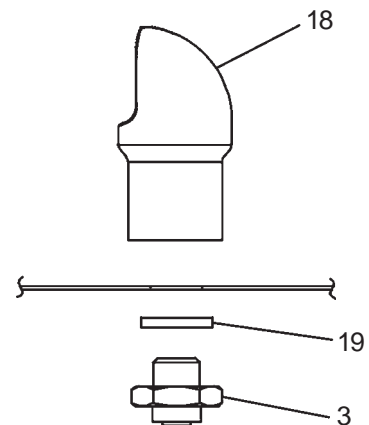

FIG. 4

# 5801VR\*C FOUNTAIN

## ITEMIZED PARTS LIST

ITEM NO.	PARTNO.	DESCRIPTION
1	56092C	Tubing-Poly (Cut To Length)
2	100147140560	Gasket
3	15009C	Bubbler Nipple Assembly
4	15005C	Nut - Retainer
5	100352940560	Gasket - Slipnut
6	40045C	Nut Hex
7	110346220550	Locknut - 1-1/2 x 11-1/2
8	160270508640	Strainer Plate - Chrome
9	160346108640	Tailpiece - 1-1/2 OD x 4
10	160346308640	Slipnut - 1-1/2
11	600985451640	Drain Plug And Adaptor
12	28464C	Basin
13	23044C	Bottom Cover
14	45663C	Push Button Sleeve
15	45662C	Push Button
16	75570C	Screw - #10-24 Pinned Torx
17	50986C	Regulator Holder
18	98118C	Bubbler Assembly
19	100322740560	Washer
20	75672C	Cap Screw
21	61313C	Regulator
22	55996C	Strainer
23	101637451550	Ring - Friction
NS	401495443730	Basin Hanger
NS	75520C	Bit-Pinned Torx T-25

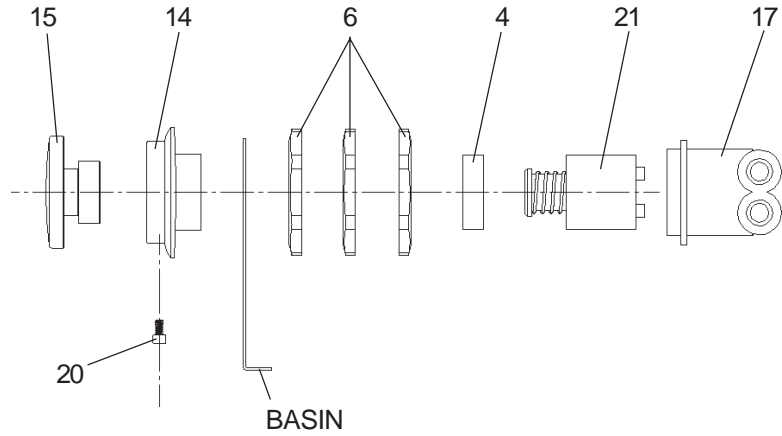
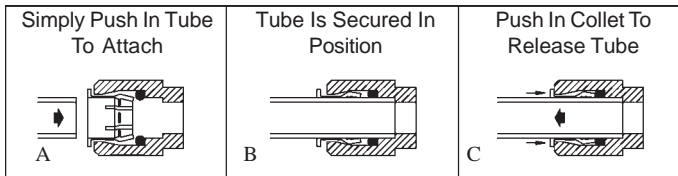

FIG. 5

### OPERATION OF QUICK CONNECT FITTINGS

Cooler is provided with lead-free connectors which utilize an o-ring water seal. To remove tubing from the fitting, relieve water pressure, push in on the gray collar while pulling out on the tubing. To insert tubing, push tube straight into fitting until it reaches a positive stop, approximately 3/4".



Insert tube to a positive stop approximately 3/4 of an inch

Pushing Tube In Before Pulling It Out Helps To Release Tube.

FIG. 6

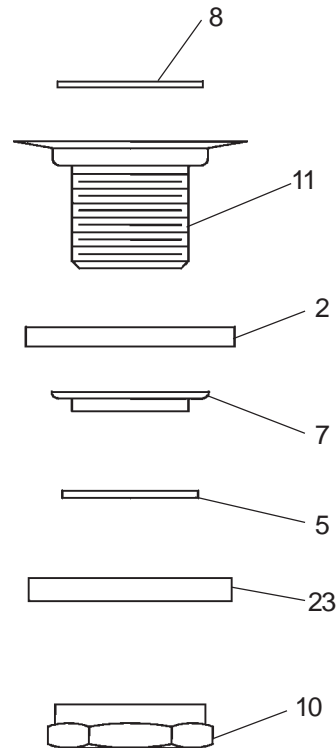

FIG. 7

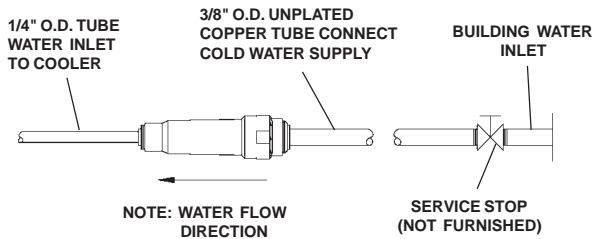

FIG. 8

**Halsey Taylor**  
 2222 CAMDEN COURT  
 OAK BROOK, IL 60523  
 630.574.3500

FOR PARTS CONTACT YOUR LOCAL DISTRIBUTOR OR VISIT OUR WEBSITE [WWW.HALSEYTAYLOR.COM](http://WWW.HALSEYTAYLOR.COM)

PRINTED IN U.S.A.